

Fischer Panda

Operation manual

Description of the generator and operation manual

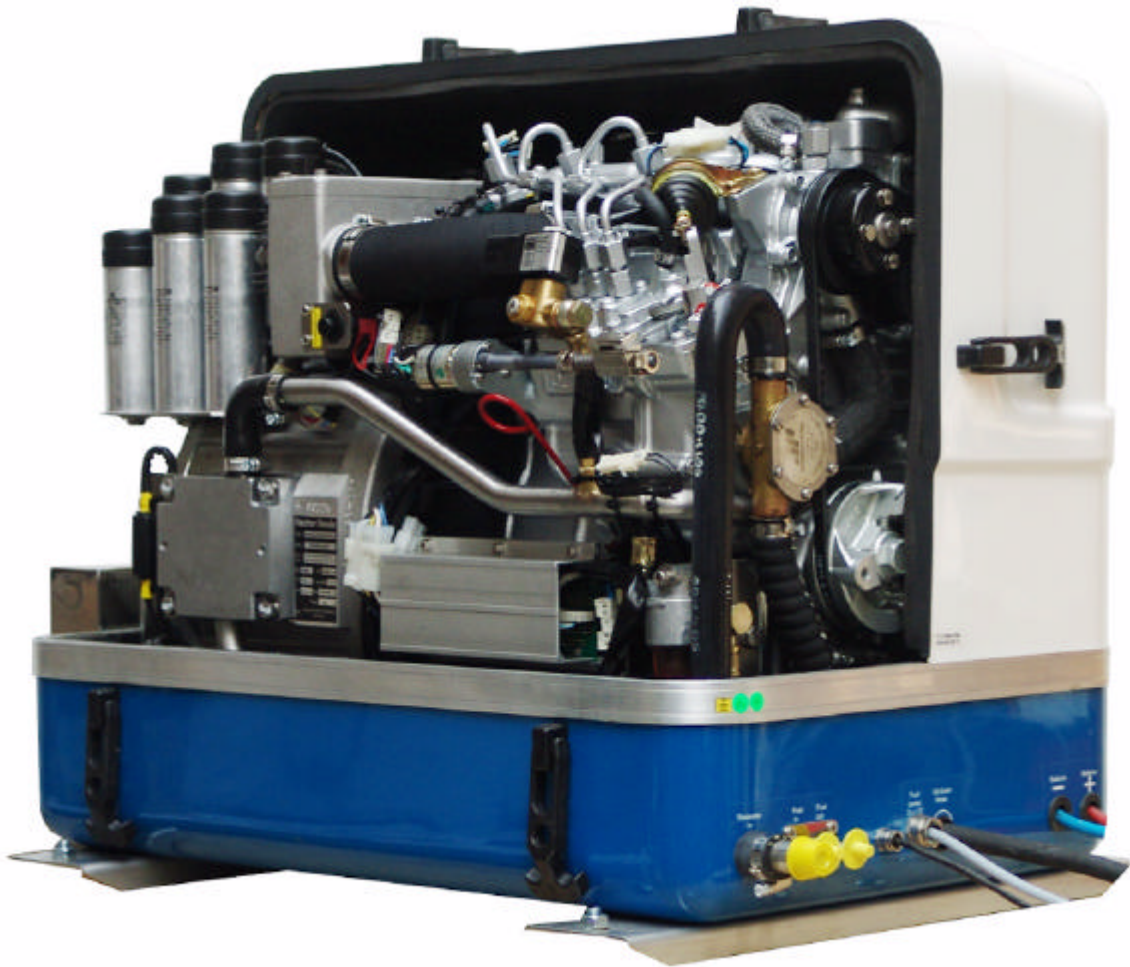

Panda PMS 12 mini E-TEC

Super silent technology

120V/240V - 60Hz / 14kW

Icemaster Fischer Panda

Current revision status

	Document
Actual:	Panda PMS 12mini E-TEC_Operation instruction s00760.V01_19.4.05
Replace:	

Revision	Page



since 1977
Icemaster GmbH



since 1978
Fischer Marine
Generators



since 1988
Conclusion Fischer -
Icemaster GmbH



since 1988
100 % water cooled
Panda generators



since 1988
Panda Vehicle
Generators

Fischer Panda

FISCHER GENERATORS have been manufactured since 1978 and are a well-known brand for first class diesel generators with especially effective sound-insulation.

Fischer has been one of the leading manufacturers in respect of quality and know-how during this period.

FISCHER, as the worldwide manufacturer of modern marine diesel generators, developed the Sailor-Silent series for example and produced a GFK sound-insulated capsule as early as 1979 and the basis for new generator technology.

The companies Fischer and Icemaster amalgamated under the direction of Icemaster in 1988, in order to concentrate on the development of new products. Production was moved to Paderborn.

The amalgamation of the two qualified companies led to the development of a complete new programme within a short space of time. The gensets developed at that time set new technological standards worldwide.

The gensets became more efficient and powerful than other gensets in the same nominal performance range, because of the improved cooling. Panda generator demonstrated its superiority in several tests by renowned institutes and magazines during the past years. The patented VCS (voltage Control System) means it can meet all demands including motor speed. The start-booster (ASB) means Panda generators meet the highest demands in respect of voltage stability and starting values. A Panda generator, with the same drive motor, produces 15% more effective output than the majority of conventional generators. This superiority in efficiency also ensures a fuel saving to the same extent.

The 100% water-cooled Panda genset are currently manufactured in the performance range from 2 to 100 kW in various versions. Fast running motors are preferred for performances up to approx 30 kW (Nominal speed 3000 rpm). The heavier slow runners are preferred for the higher range. The fast running gensets have proved themselves many times for many uses, that they meet the demands in quality of yachts and vehicles, and offer space and weight saving of 50% compared to slow running generators.

In addition to the Panda series, Icemaster also supply the super compact high-tech sound-insulated battery charging genset from the DC/AC Panda AGT series, which is a very interesting solution for the production of mobile power.

The new HTG-alternators ensure that a charging rate of 285 amps is achieved that was scarcely thought possible for this compact construction. This alternator replaces a separate shipboard generators (constant 230 volts AC with up to 3500 kW from the main machine)

ICEMASTER GmbH, 33104 Paderborn, reserves all rights regarding text and graphics. Details are given to the best of our knowledge. No liability is accepted for correctness. Technical modifications for improving the product without previous notice may be undertaken without notice. Before installation, it must be ensured that the Pictures, diagrams and related material are applicable to the genset supplied. Enquiries must be made in case of doubt.

CALIFORNIA

Proposition 65 Warning

Diesel engine exhaust and some of its constituents are known to the State of California to cause cancer, birth defects, and other reproductive harm.



Attention, Important Directions regarding Operation!

1. The installation certificate must be completed when taken into use, and certified by a signature.
2. The installation certificate must be despatched within two weeks of use to ICEMASTER.
3. The official guaranty confirmation will be completed by ICEMASTER after receipt and sent to the customer.
4. A guaranty must be shown to make any claims.

Claims against the guaranty will not be accepted if the above said instructions are not, or only partially, carried out.

Manufacturer declaration in terms of the machine guideline 98/37/EG .

The generator is in such a way developed that all assembly groups correspond to the CE guidelines. If machine guideline 98/37/EG is applicable, then it is forbidden to bring the generator into operation until it has been determined that the system into which the generator is to be installed in also corresponds to the regulations of the machine guideline 98/37/EG. This concerns among other things the exhaust system, cooling system and the electrical installation.

The evaluation of the "protection against contact" can only be accomplished in connection with the respective system. Likewise among other things responsibility for correct electrical connections, a safe ground wire connection, foreign body and humidity protection, protection against humidity due to excessive condensation as well as the overheating through appropriate and inappropriate use in its installed state on the respective machine lies within the responsibility of those who undertake installation of the generator in the system.

Use the advantages of the customer registration:

- Thus you receive to extended product informations, which are sometimes safety-relevant
- you receive, if necessarily free Upgrades

Far advantages:

By your full information Fischer Panda technicians can give you fast assistance, since 90% of the disturbances result from errors in the periphery.

Problems due to errors in the installation can be recognized in the apron.

Technical Support by Internet: info@fischerpanda.com

Safety Instructions



The electrical Installations may only be carried out by trained and tested personnel!

The generator may not be taken into use with the cover removed.

The rotating parts (belt-pulley, belts, etc) must be so covered and protected do that there is no danger to life and body!

If a sound insulation covering must be produced at the place of installation, then well-placed signs must show that the generator can only be switched on with a closed capsule.

All servicing-, maintenance or repair work may only carried out, when the motor is not running.

Electrical voltages above 48 volts (battery chargers greater than 36 volts) are always dangerous to life). The rules of the respective regional authority must be adhered to. Only an electrician may carry out installation of the electrical connections for safety reasons.

Protective Conductor:

The generator is „earthed " as standard (The centre and earth are connected by means of a bridge in the generator terminal box). This is a basic safety function, which offers basic safety as long as no other component has been installed. It is, above all, conceived for supply and an eventual test run.

This "earth" (PEN) is only effective, if all parts of the electrical system is earthed, and has a common "potential". The bridges can be removed, if this is required for technical reasons and another protection system has been installed.

The full voltage is exploited at the AC control box, when the generator is run. It must therefore be ensured that the control box is closed and cannot be tampered with, if the generator is running.

The battery must always be disconnected, if work on the generator or electrical system is to be carried out, so that the generator cannot be unintentionally started.

Switch off all load when working on the generator

All load must be disconnected, in order to avoid damages to the devices. In addition the semi conductors in the AC control box must be disconnected in order to avoid the boat capacitors being activated. The minus pole of the battery ought to be removed.

Capacitors are required to run the generator. These have two varying functions:

A) The working capacitors

B) The (Booster) capacitors

Both Groups are located in a sound cover of the genset.

Capacitors are electrical stores. There could be a residual of high electrical current at the contacts for a period disconnection from the circuit. The contacts my not be touched for safety reasons, If the capacitors are to be exchanged or checked, then a short circuit between the contacts should be made so that the stored energy is discharged.

If the generator is switched off in the normal manner, the working capacitors are automatically discharged by means of the windings. The booster capacitors are discharged by means of internal discharge resistors.

All capacitors must be short-circuited before work is carried out on the AC-Control box for safety reasons.

Table of Contents

A	The Panda Generator	3
	A.1 Description of the Generator	3
	A.1.1 Right Side View	3
	A.1.2 Left Side View	4
	A.1.3 Front View	5
	A.1.4 Back View.....	6
	A.1.5 View from Above	7
	A.2 Details of functional units	8
	A.2.1 E-TEC Remote control panel	8
	A.2.2 Components of Cooling System (Raw water)	9
	A.2.3 Components of Cooling System (Freshwater)	11
	A.2.4 Components of the fuel system	15
	A.2.5 Components of combustion air.....	17
	A.2.6 Components of the electrical system	20
	A.2.7 Sensors and switches for operating surveillance	26
	A.2.8 Components of the oil circuit.....	30
	A.3 Operation manual	31
	A.3.1 Preliminary remark	31
	A.3.2 Daily routine checks before starting	32
	A.3.3 Starting Generator	33
	A.3.4 Stopping the Generator	33
B	E-Tec Remote control panel	35

A. The Panda Generator

A.1 Description of the Generator

A.1.1 Right Side View

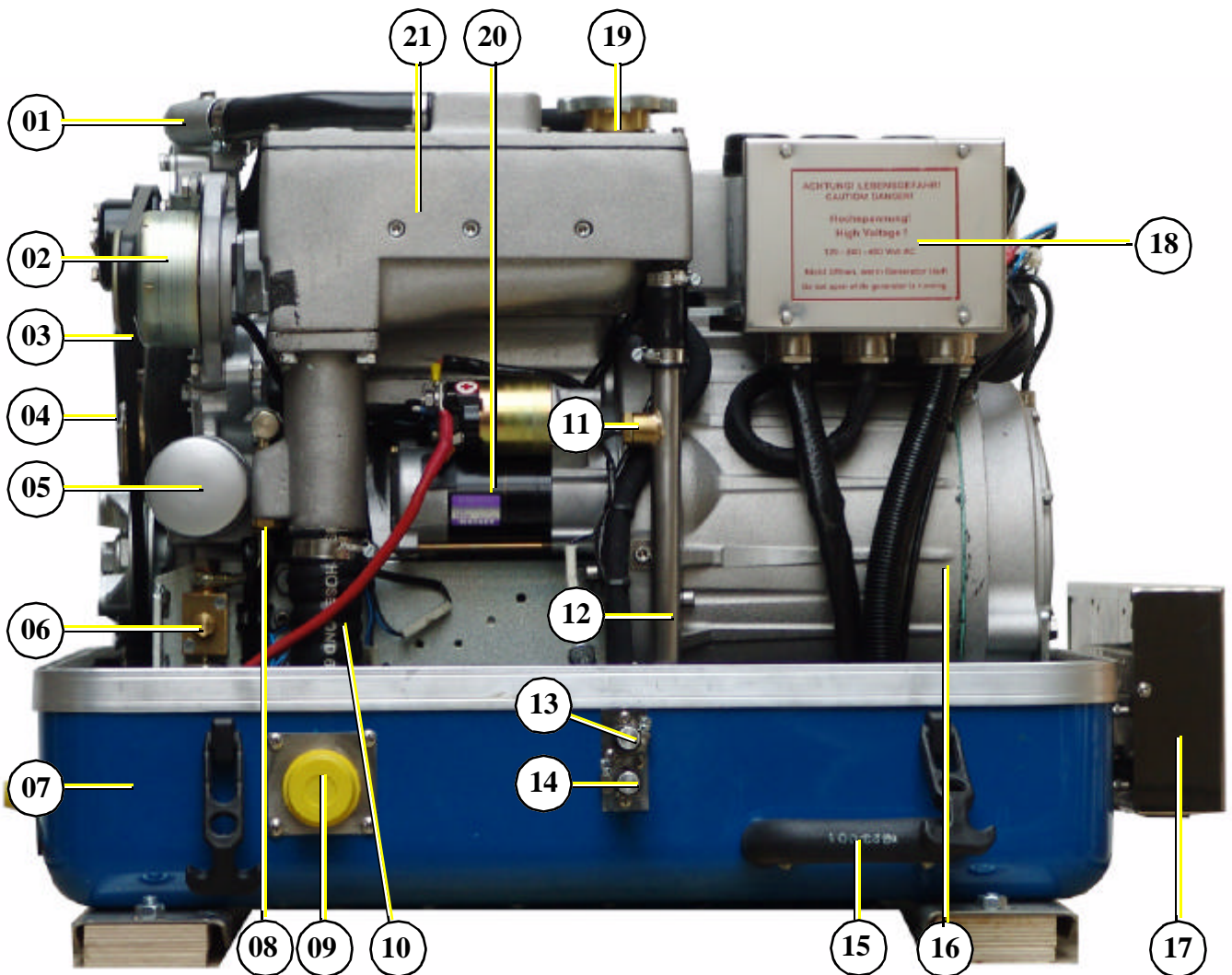

- 01. Thermostat housing
- 02. DC-alternator
- 03. V-belt for DC-alternator and cooling water pump
- 04. Raw water pump
- 05. Engine oil filter
- 06. Oil sensor with oil pressure switch
- 07. Sound cover - base part
- 08. Thermo-sensor raw water out
- 09. Exhaust output
- 10. Exhaust hose
- 11. Thermo-sensor freshwater out

- 12. Freshwater return pipe
- 13. Intake to external cooling water expansion tank
- 14. Backflow from external cooling water expansion tank
- 15. Connection external ventilation valve
- 16. Generator housing with coil
- 17. Control box
- 18. Power terminal box
- 19. Cooling water filler neck
- 20. Starter motor
- 21. Water-cooled exhaust elbow

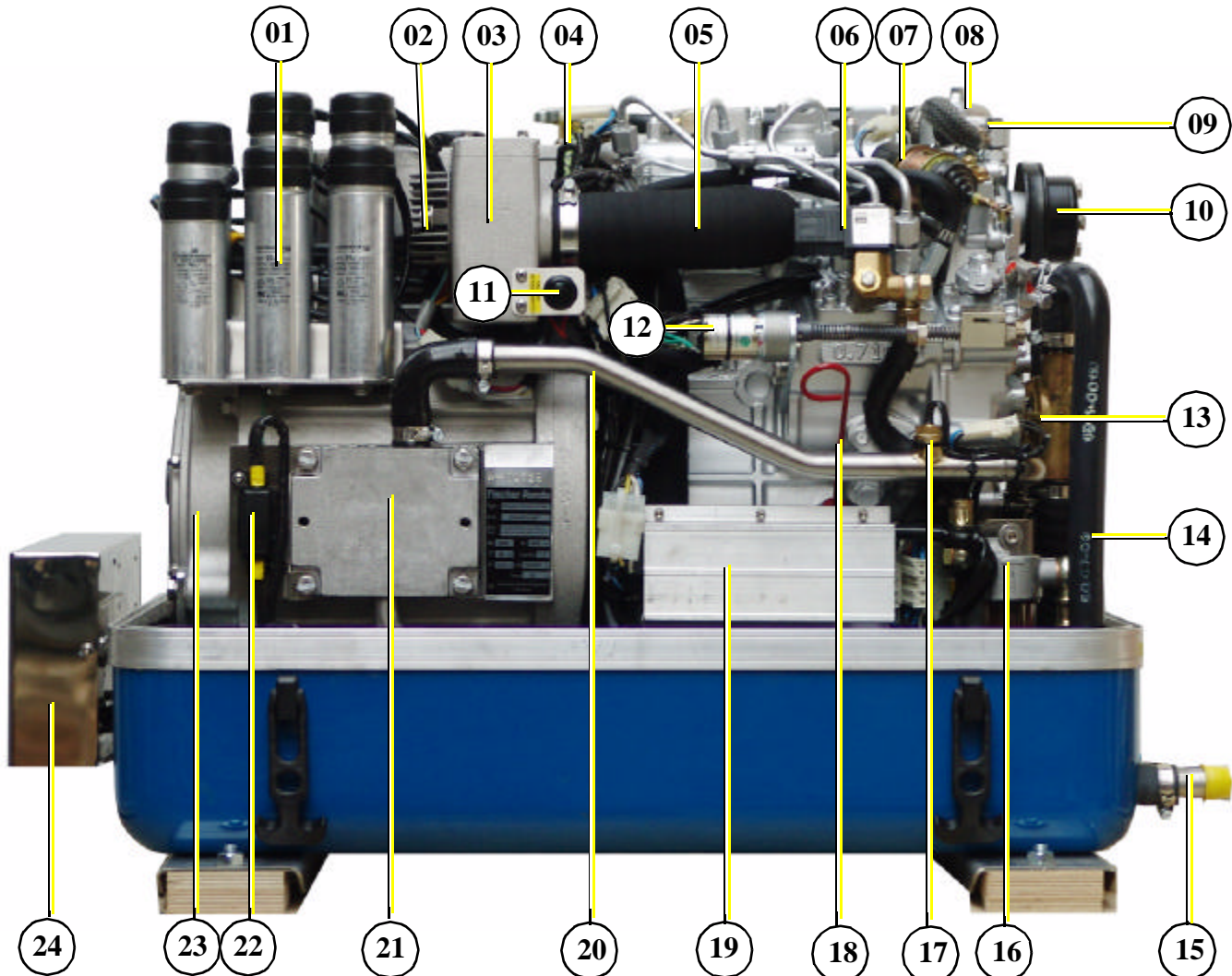
A.1.2 Left Side View

- | | |
|---|---|
| 01. Excitation capacitors (2x140 μ F) | 13. Raw water pump |
| 02. Charge controller for DC-alternator | 14. Raw water intake hose |
| 03. Air suction housing with air filter | 15. Raw water inlet |
| 04. Thermo-switch cylinder head | 16. Fuel filter with water separator |
| 05. Air suction hose induction elbow | 17. Thermo-sensor freshwater in |
| 06. Fuel solenoid valve | 18. Oil dipstick |
| 07. Stop solenoid | 19. Relay board |
| 08. Thermostat housing | 20. Cooling water pipe, connection block - water pump |
| 09. Ventilation screw internal cooling water pump | 21. Cooling water connection block |
| 10. Pulley for internal cooling water pump | 22. Fuse for relay board |
| 11. Fuel purge switch | 23. Generator housing with coil |
| 12. Actuator for speed control | 24. Control box |

A.1.3 Front View

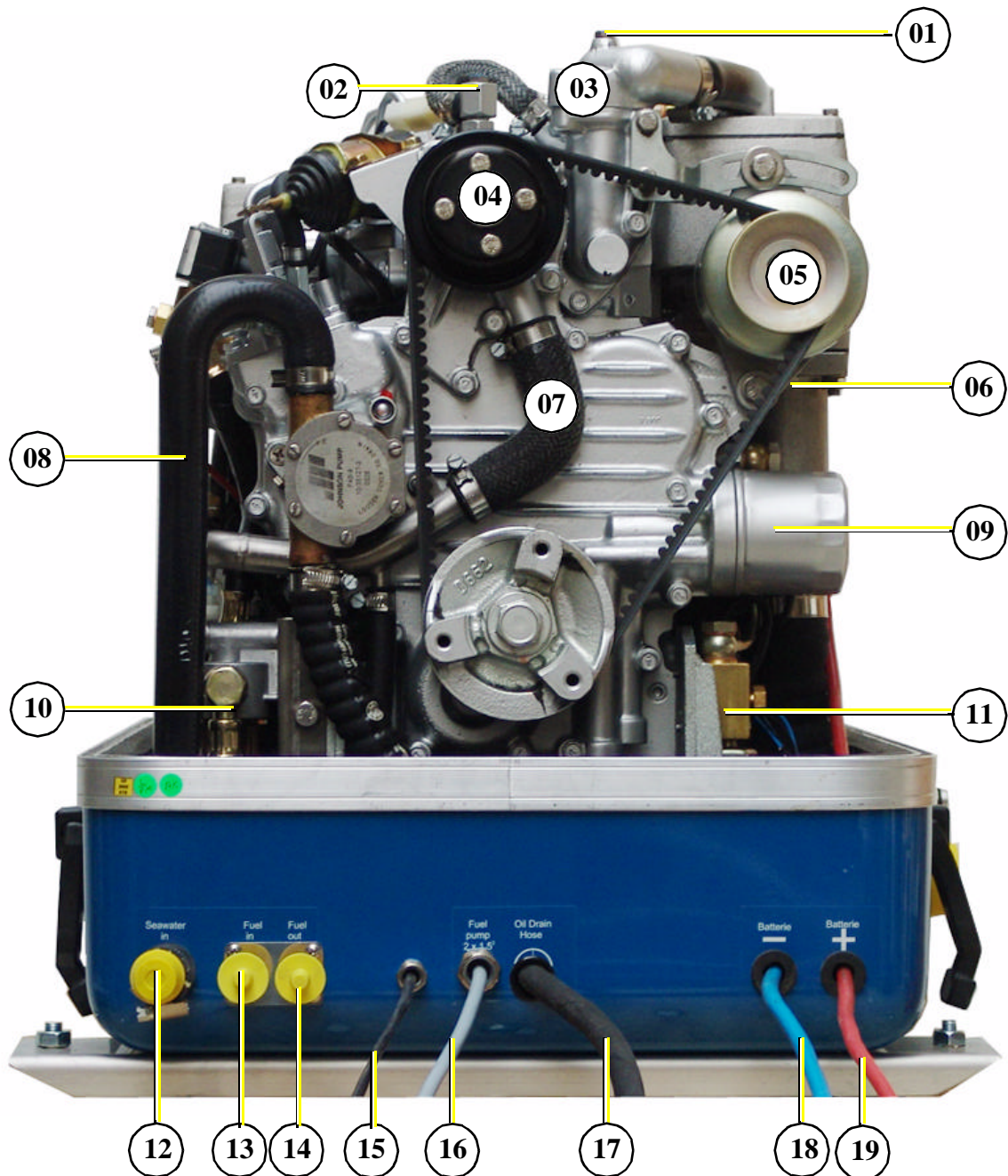

- | | |
|--|---|
| 01. Ventilation screw thermostat housing | 11. Oil sensor with oil pressure switch |
| 02. Ventilation screw internal cooling water pump | 12. Raw water inlet |
| 03. Thermostat housing with thermostat set | 13. Fuel intake connection |
| 04. Pulley for internal cooling water pump | 14. Fuel backflow connection |
| 05. DC-alternator | 15. Cable for fuel sensor |
| 06. V-belt for DC-alternator and internal cooling water pump | 16. Cable fuel pump |
| 07. Raw water pump | 17. Oil drain hose |
| 08. Hose for raw water intake | 18. Cable starter battery minus (-) |
| 09. Engine oil filter | 19. Cable starter battery plus (+) |
| 10. Fuel filter with water separator | |

A.1.4 Back View

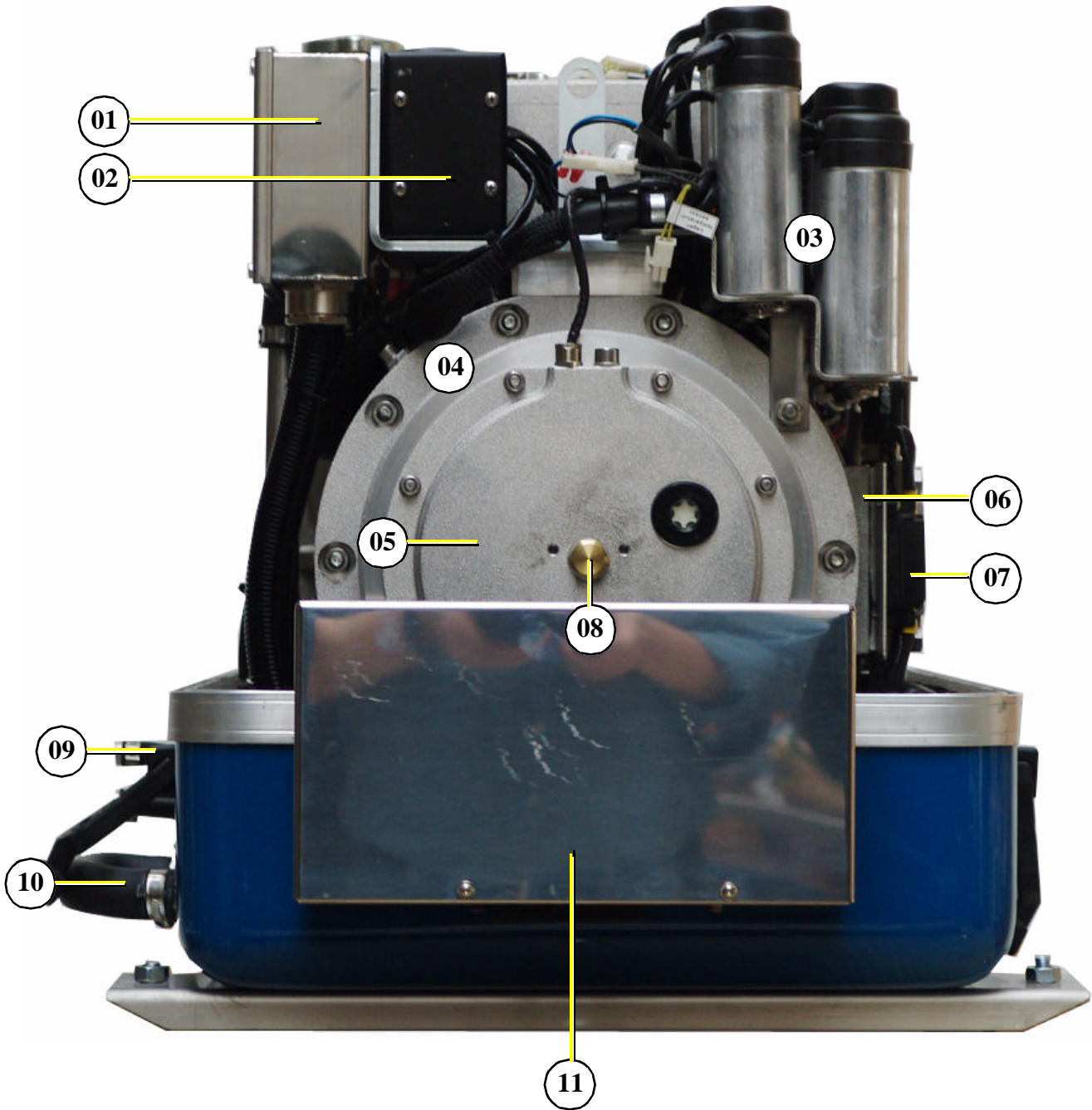

- | | |
|---|--|
| 01. Power terminal box | 07. Fuse for relay board |
| 02. Solid state relays for booster capacitors | 08. Thermo-switch bearing |
| 03. Excitation capacitors (2x140µF) | 09. Connections external expansion tank |
| 04. Generator front cover | 10. Connection external ventillation valve |
| 05. Cover oil lubricated bearing | 11. Control box |
| 06. Cooling water connection block | |

A.1.5 View from Above

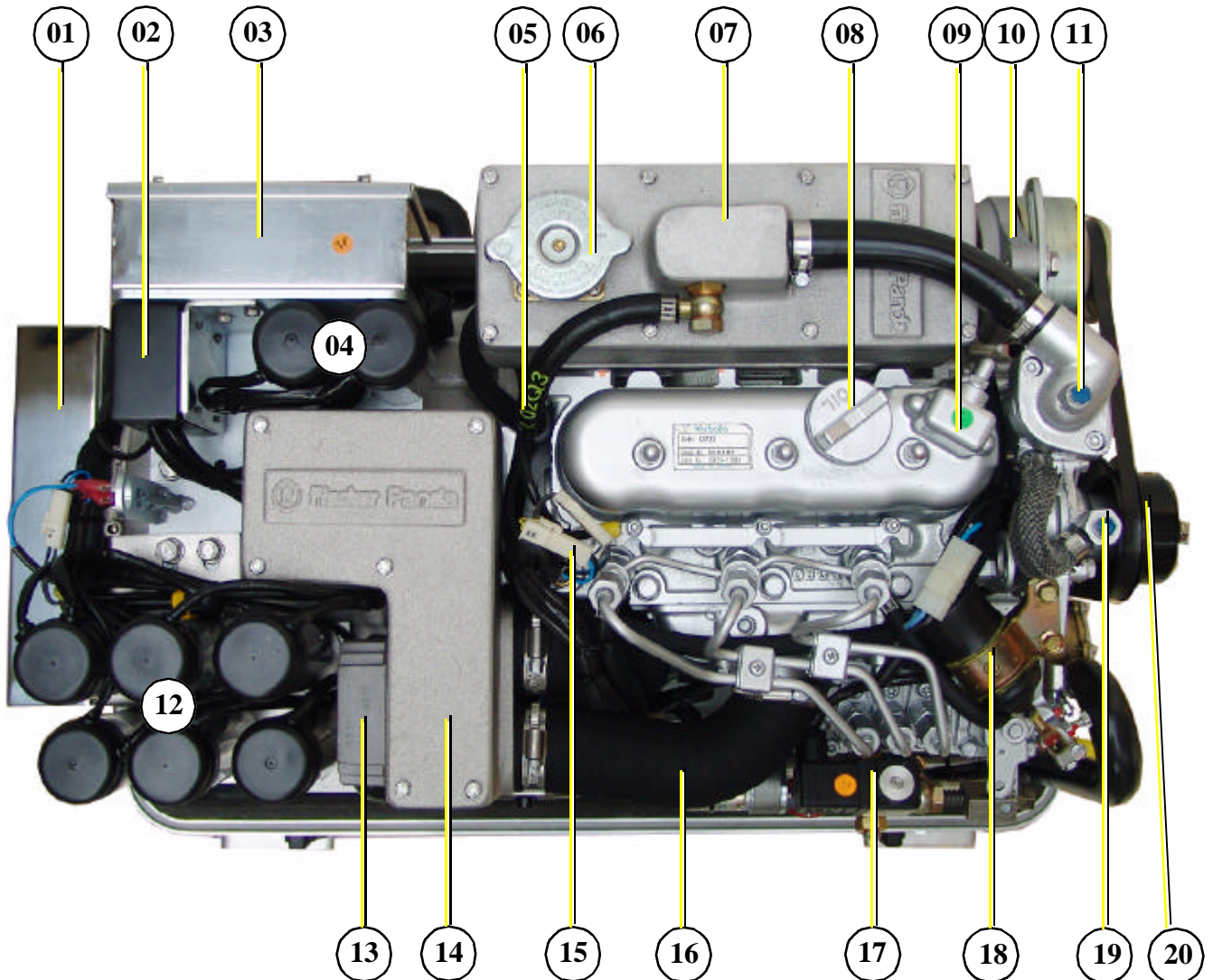

- 01. Control box
- 02. Solid state relays for booster capacitors
- 03. Power terminal box
- 04. Booster capacitors (2x40 μ F)
- 05. Ventilation hose to external expansion tank
- 06. Cooling water filler neck
- 07. Water-cooled exhaust elbow
- 08. Engine oil filler neck
- 09. Cylinder head
- 10. DC-alternator

- 11. Ventilation screw thermostat housing
- 12. Excitation capacitors (2x140 μ F)
- 13. Charge controller for DC-alternator
- 14. Air suction housing with air filter
- 15. Cylinder head thermo-switch
- 16. Air suction hose induction elbow
- 17. Fuel solenoid valve
- 18. Stop solenoid
- 19. Ventilation screw internal cooling water pump
- 20. Pulley for internal cooling water pump

A.2 Details of functional units

A.2.1 E-TEC Remote control panel

The remote control panel is equipped with some new monitoring functions, which increases the operational safety of the generator. A failure message is shown over contacts which are normally closed. If a connection is intermitted triggers this a failure message.



- | | |
|---|--|
| <p>01. Digital display</p> <p>02. S1 Button „ON/OFF“ „Stand by“</p> <p>03. S2 Button alarm mute / program level</p> | <p>04. S3 Button display shift</p> <p>05. S4 Button rpm shift / cold start</p> <p>06. S5 Button run/stop / select save</p> |
|---|--|

Fig. A.1: E-TEC Remote control panel

A.2.2 Components of Cooling System (Raw water)

Raw water intake

The diagram shows the supply pipes for the generator. The connection neck for the raw water connection is shown on the left hand side. The cross-section of the intake pipe should be nominally larger than the generator connection.

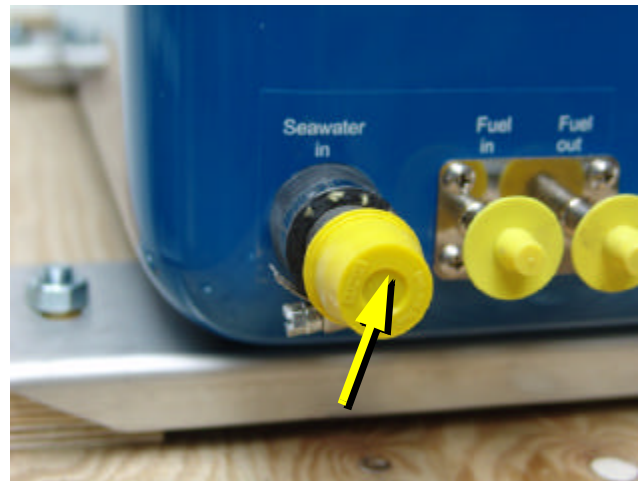

Fig. A.2: Raw water intake

Raw water impeller pump

The raw water pump is fitted with a rubber impeller. This pump is self-inductive. If, for example, you forget to open the sea valve, then you must expect the impeller to be destroyed after a short period of time. It is recommended to store several impellers on board as spare parts.

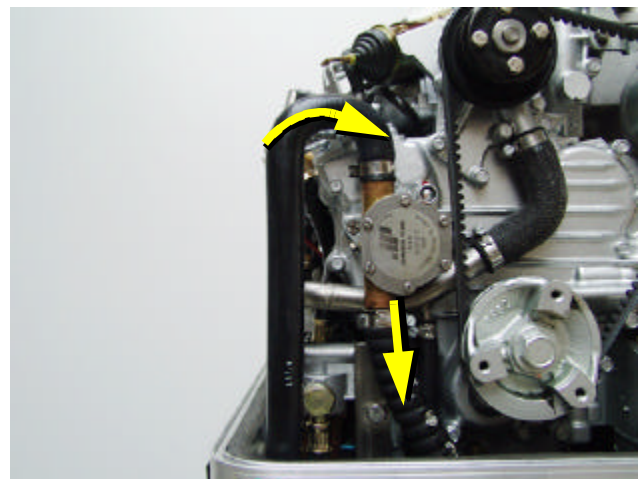

Fig. A.3: Raw water impeller pump

Heat exchanger

Separates the raw water system from the freshwater system.

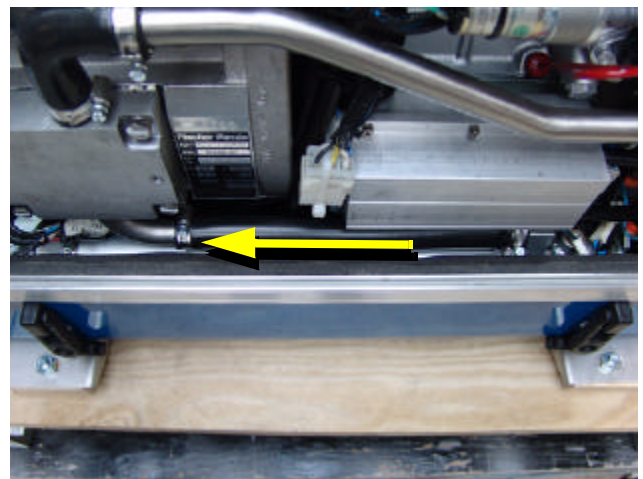
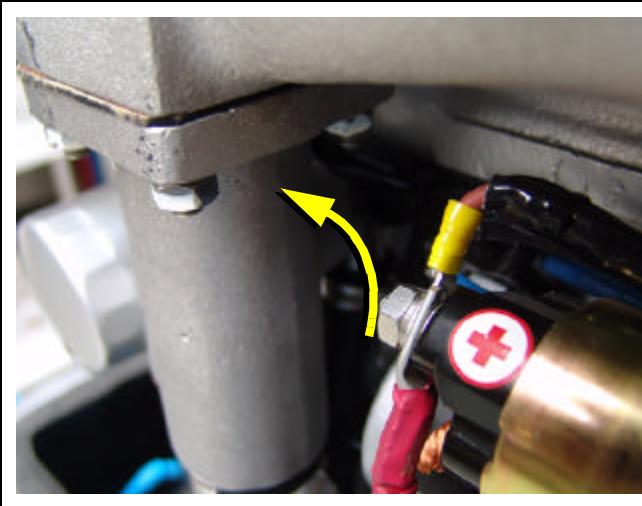

Fig. A.4: Heat exchanger

**Ventilation valve**

A siphon must be installed if the generator sinks below the water line because of the rocking of the boat, even if it is only for a short period of time. A hosepipe on the generator casing has been produced for this. Both connecting pieces are bridged by a formed piece of hose.

Fig. A.5: Connection external vent valve

**Raw water injector nozzle**

The injection point for the marine generator water-cooled exhaust system is situated at the exhaust connection pieces. The exhaust connections must be regularly checked for signs of corrosion.

Fig. A.6: Raw water injector nozzle

A.2.3 Components of Cooling System (Freshwater)

Cooling water filler neck

The cooling water filler neck is situated at the water-cooled manifold and only used, when the generator is initially started. Since the generator is normally already filled with cooling water, these components are only by the user, if repairs are to be carried out. Topping up with cooling water may only carried out at the external cooling water compensation tank. Note that the water level in the cooling water compensation tank is only 20% of the volume in a cold state.

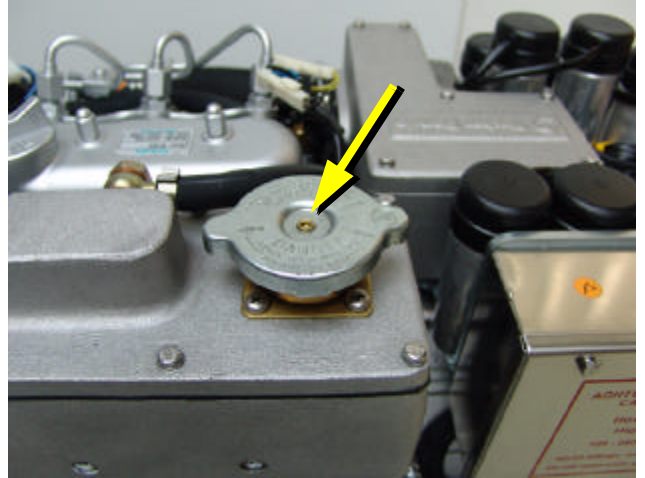

Fig. A.7: Cooling water filler neck

Freshwater backflow

The cooling water is fed to the heat exchanger from the water-cooled manifold by means of the pipe shown in the diagram.

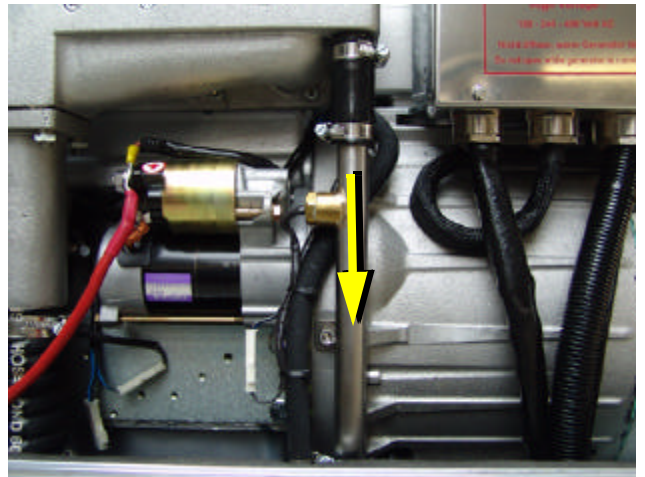

Fig. A.8: Freshwater backflow

Ventilation pipe

The ventilation pipe at the water-cooled exhaust manifold leads to the external expansion tank. This pipe only serves as a ventilation pipe, if both pipes are to be connected to the external expansion tank (ventilation pipe and intake pipe).

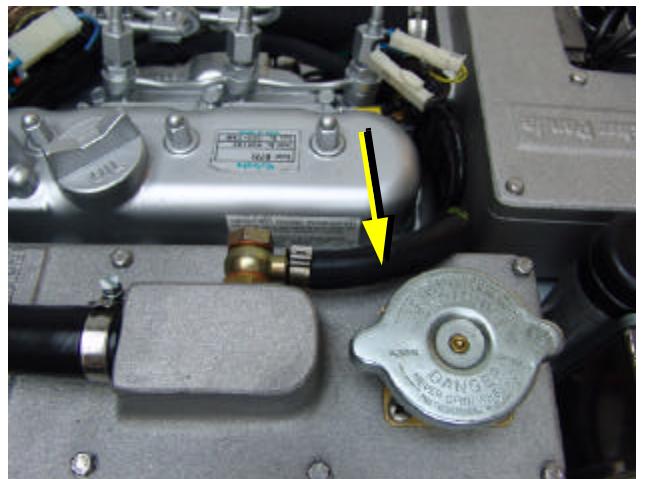
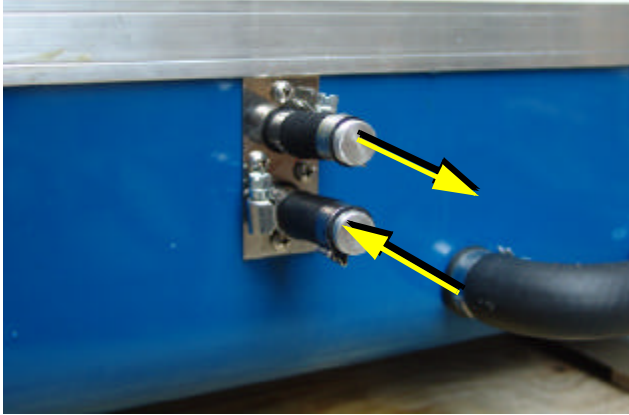

Fig. A.9: Ventilation pipe



Hose connection pieces for the external expansion tank

The external expansion tank is connected by two hose connections. The connecting pieces shown here serves as constant ventilation for the water-cooling system.

In case the external expansion tank is connected with two hoses, the system will ventilate itself. In this case, additional ventilation is only necessary when the generator is initially filled, or if the cooling water is not circulating.

Fig. A.10: External expansion tank

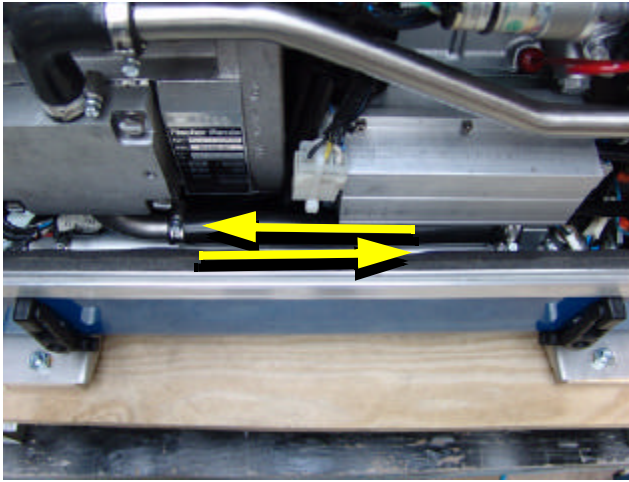

Heat exchanger

Separates the raw water system from the freshwater system.

Fig. A.11: Heat exchanger

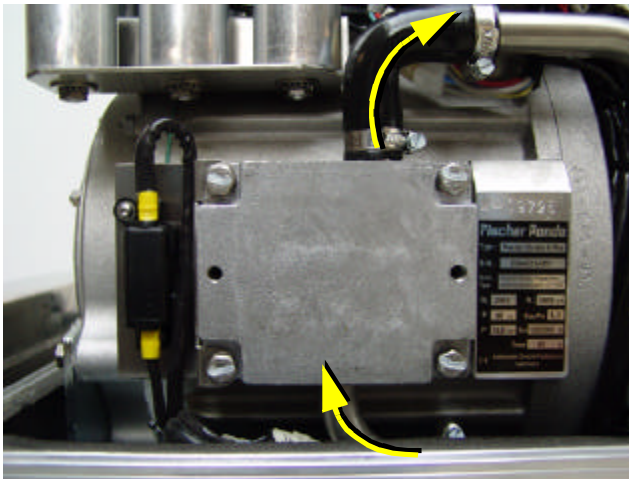

Cooling water connection block

The cooling water is fed to the generator and drained via the cooling water connection block. The cooling water connection block consists of an aluminium alloy, which can behave like a sacrificial anode.

Fig. A.12: Cooling water connection block

Cooling water pipe

From the cooling water connection block the fresh water is lead to the water pump

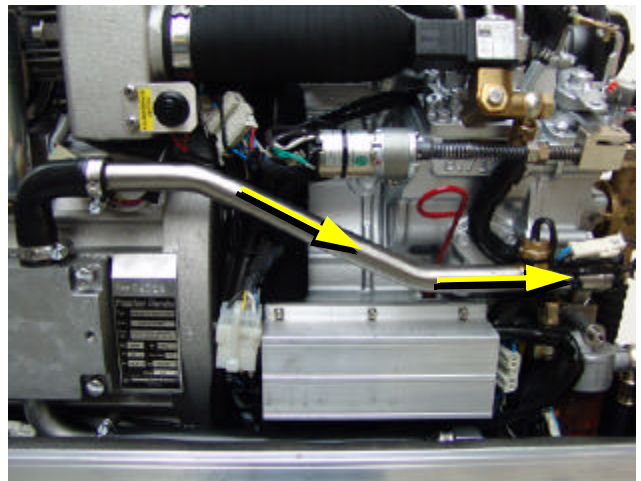

Fig. A.13: Cooling water pipe

Internal cooling water pump

The diesel motor cooling water pump (see arrow) aids the circulation of the internal freshwater system.

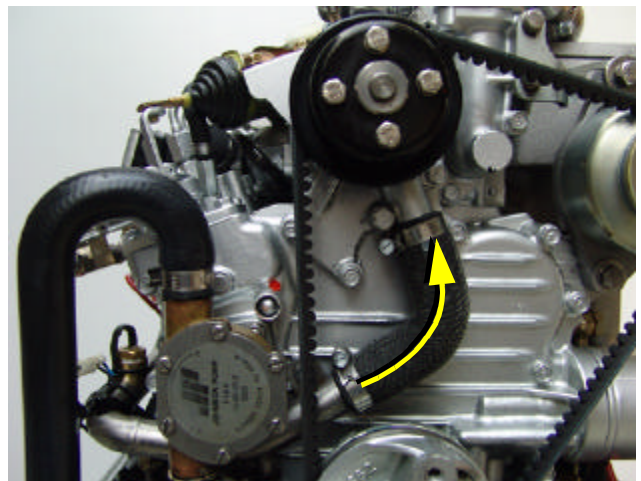

Fig. A.14: Internal cooling water pump

Cooling water intake

A.) To the water pump

B.) From the external expansion tank

The intake pipe from the external cooling water expansion tank is connected to the point shown with „B“.

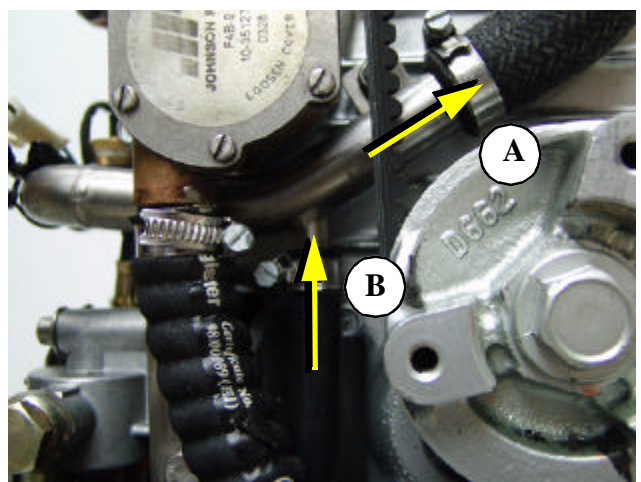
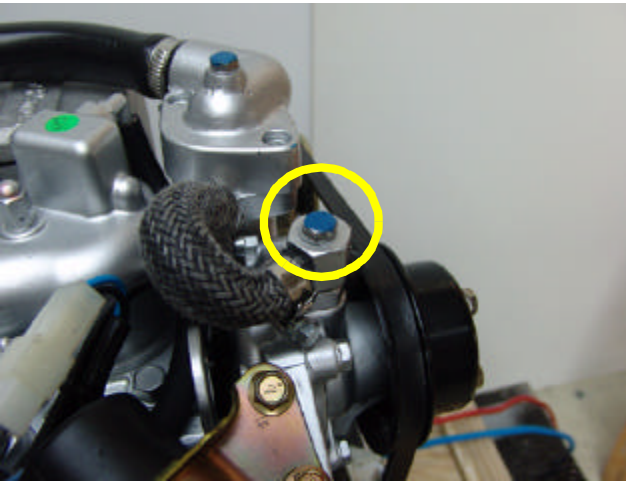



Fig. A.15: Internal cooling water pump



Ventilation screw cooling water pump

The ventilation screw above the cooling water pump casing may not be opened, whilst the generator is running. If this occurs by mistake, air will be drawn through the opening. Extensive ventilation of the whole system is then necessary.

Fig. A.16: Ventilation screw cooling water pump



Ventilation screw thermostat housing

The ventilation screw on the thermostat housing should occasionally be opened for control purposes. Standing machinery should principally carry out ventilating.

Fig. A.17: Ventilation screw thermostat housin

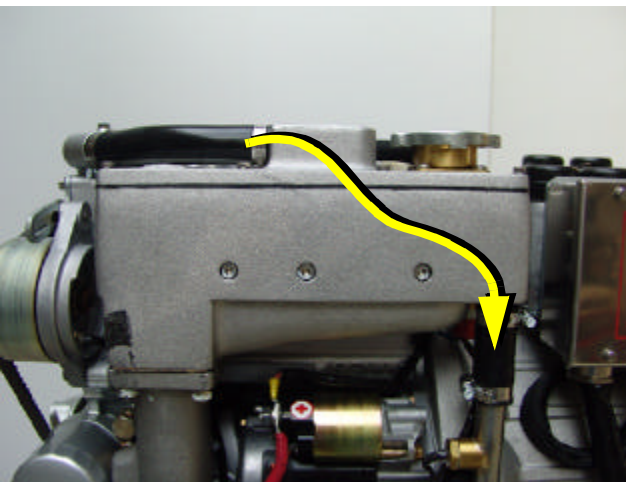

Water-cooled exhaust manifold

The manifold is cooled by means of the internal cooling system (freshwater). The cooling water filler necks on the casing of the manifold may not be opened. These cooling water necks are only required to fill the motor with cooling water in cases of repair. The normal cooling water controls may only be carried out at the external expansion tank.

Fig. A.18: Water-cooled exhaust manifold

A.2.4 Components of the fuel system

External fuel pump

The Panda generator is always supplied with an external, electrical (12 V of DC) fuel pump. The fuel pump must be always installed in the proximity of the tank. The electrical connections with the lead planned for it are before-installed at the generator. Since the suction height and the supply pressure are limited, it can be sometimes possible that for reinforcement a second pump must be installed.



Fig. A.19: External fuel pump

Connecting pieces for the fuel pipe

1. Fuel intake
2. Fuel backflow

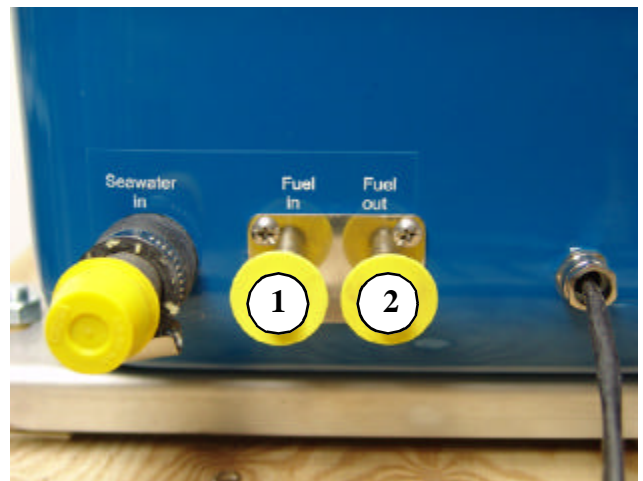

Fig. A.20: Fuel connections

Fuel filter with water separator

A consequential filtering of fuel is especially important for all marine systems. A fine filter, which is firmly attached to the inside of the sound insulation capsule for the marine version, is supplied on delivery, and loose for other makes. In all cases a further pre-filter with water separator must be installed. See directions for fuel filter installation.

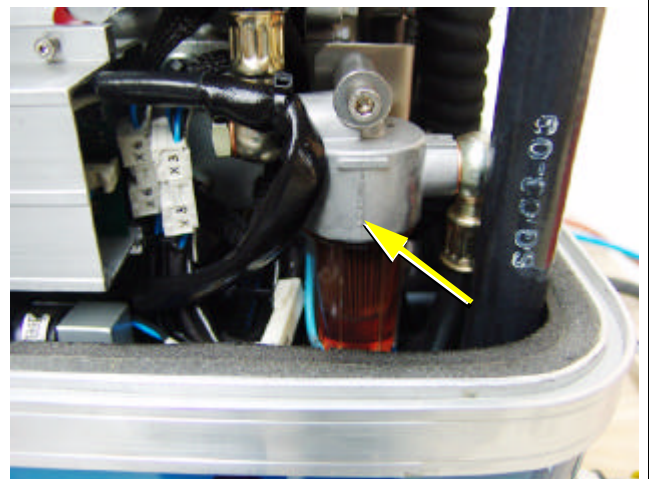
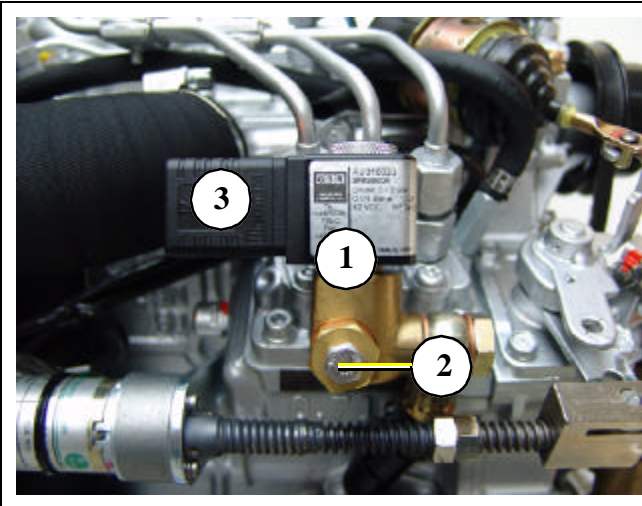

Fig. A.21: Fuel filter with water separator



Fuel solenoid valve

The fuel solenoid valve opens automatically if „START“ is pressed on the remote control panel“. The solenoid closes, if the generator is switched to „OFF“ position. It takes a few seconds before the generator stops. If the generator does not start or does not run smoothly (i.e. stutters), or does not attain full speed, then the cause is fore-mostly the solenoid.

- 1) Fuel solenoid valve
- 2) Ventilation screw solenoid valve
- 3) Magnetic coil

Fig. A.22: Fuel solenoid valve

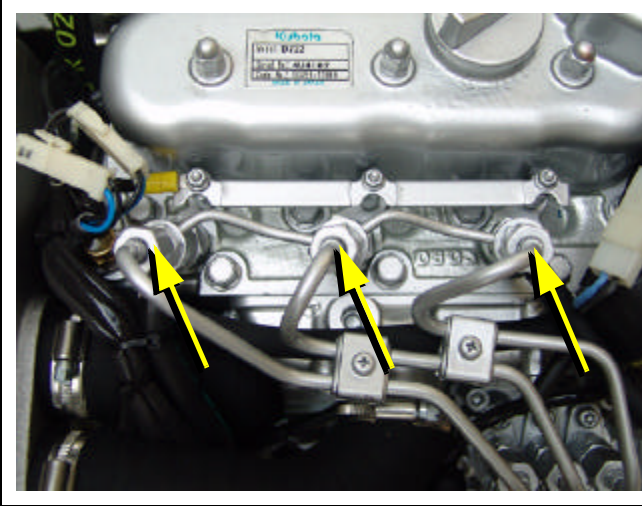

Injection nozzles

If the engine does not start after the ventilation, the fuel injection lines must be de-aerated individually.

Fig. A.23: Injection nozzles

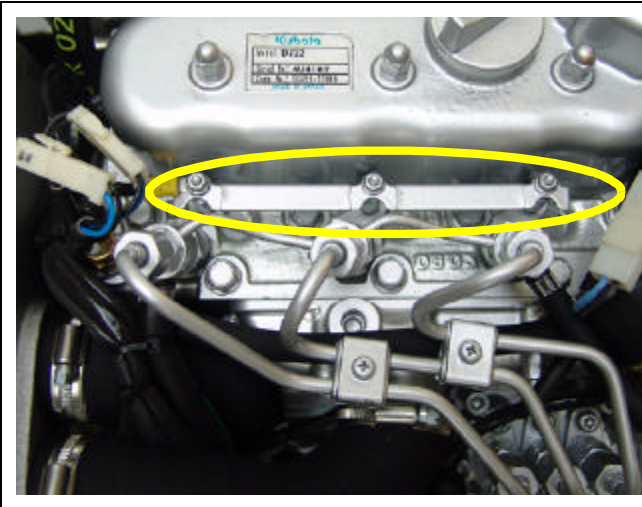

Glow plugs

The glow plugs serve the pre-chamber for the heating with cold start. The heat-treat fixture must be operated, if the temperature of the generator is under 16°C. This is practically with each start the case. The heat-treat fixture may be held down also during start and favoured the starting procedure.

Fig. A.24: Glow plugs

Stop solenoid for engine stop

Some model are additional equipped with an stop solenoid. The generator is stopped by the co-operation of the stop solenoid immediately after switching off. The adjustment of the stop solenoid must always be checked, in order to be sure that the stop lever can move also during the operation freely and is not under pre-stressing.



Fig. A.25: Stop solenoid

A.2.5 Components of combustion air

Air suction openings at the sound cover

The sound cover for the marine generator is provided at the back side of the sound cover with drillings, through which the combustion air can influx.

It must be consistently paid attention that the generator is installed in such a way that from down no water can arrive into the proximity of these air openings. (minimum distance 150 mm)



Fig. A.26: Combustion air intake

Air suction housing with 12V DC charge control

The shown air suction housing shows the 12V DC charge control (pos. 2) at the exterior. This charge control is to be checked, if the 12V DC voltage is not correct.

If the cover (pos. 1) is removed, the inside of the air suction housing becomes visible. In these air suction housings is a filter element. At the marine version the filter is normally not changed. It should be checked once in a while.

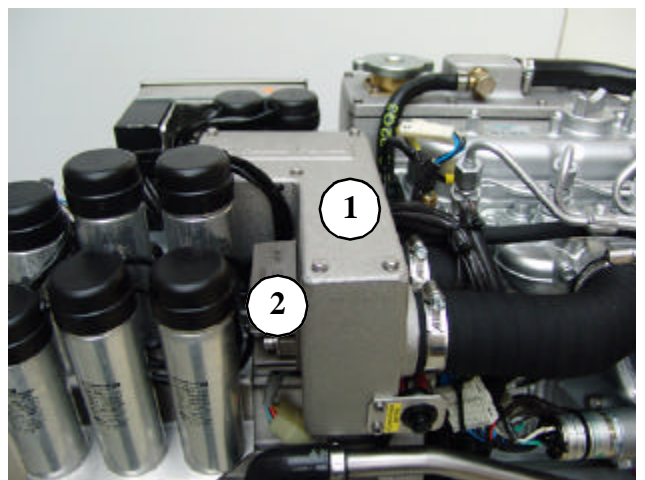

Fig. A.27: Air suction housing



Air suction housing with air filter set

The figure shows the air filter element in the air suction housing. However the return pipe of the crank case exhaust flows also into the air suction housing, it can be faced with older generators and/or with engines on high running time that oil vapors affect the air filter. Therefore an check is advisable once in a while.

Fig. A.28: Air filter set

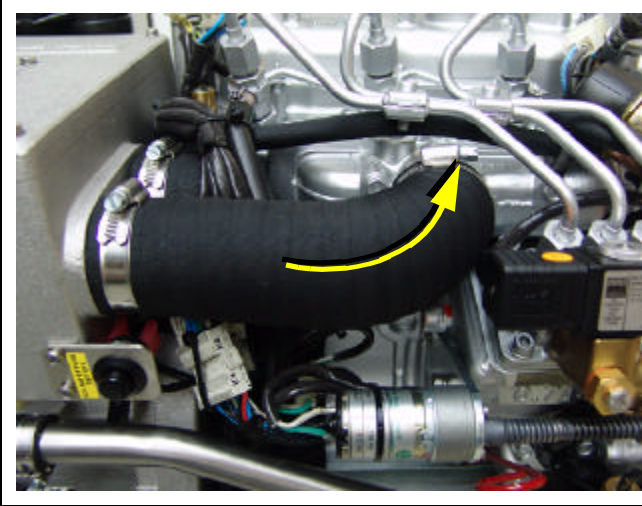

Combustion chamber intake elbow

The figure shows the induction elbow at the combustion engine. At the front of this induction elbow you can see the hose connection between air suction housings and induction elbow. The air filter must be checked, if this hose pulls together at operation.

Fig. A.29: Combustion chamber intake elbow

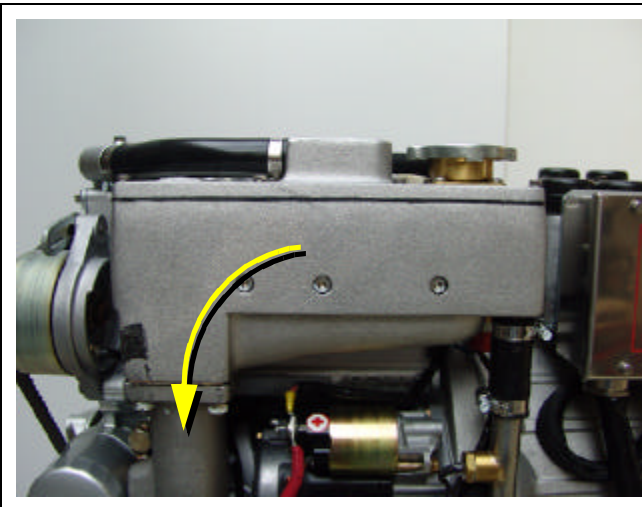

Exhaust elbow

On the back of the engine is the water-cooled exhaust elbow. On the top side the pipe union for the internal raw water circuit is to be seen and the filler neck for the cooling water. This cooling water filler neck is used only at first filling. Control of the cooling water and if necessary refill takes place at the external cooling water expansion tank.

Fig. A.30: Exhaust elbow

Exhaust connection at the exhaust elbow

Raw water from the external cooling circle is fed here.

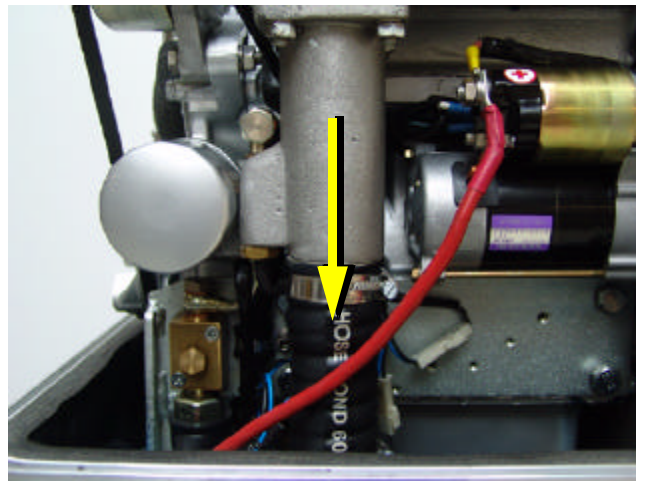

Fig. A.31: Exhaust connection

Exhaust outlet

Connect the exhaust pipe with the water lock.

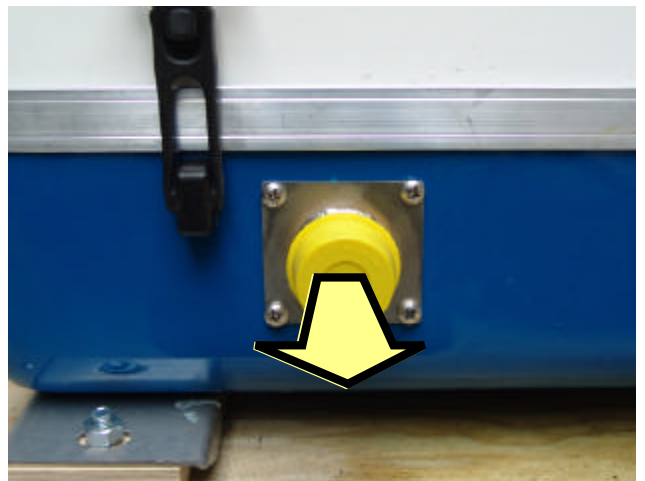
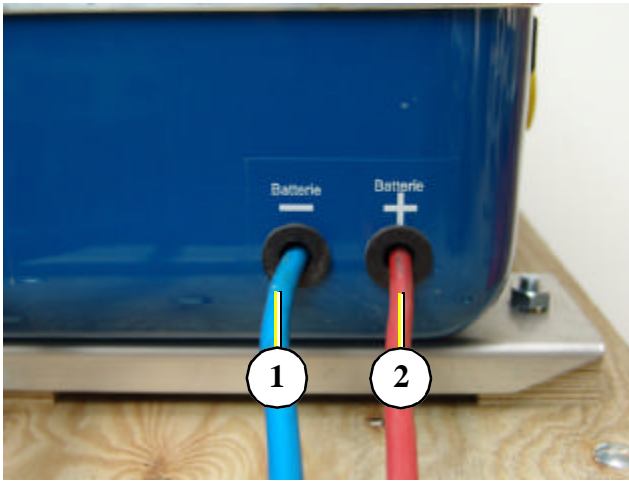

Fig. A.32: Exhaust outlet

A.2.6 Components of the electrical system



Connection starter battery

1. Cable for starter battery (minus)
2. Cable for starter battery (plus)

During the connection to the starter battery it must be always ensured that the contact is perfectly guaranteed.

Fig. A.33: Cable for starter battery

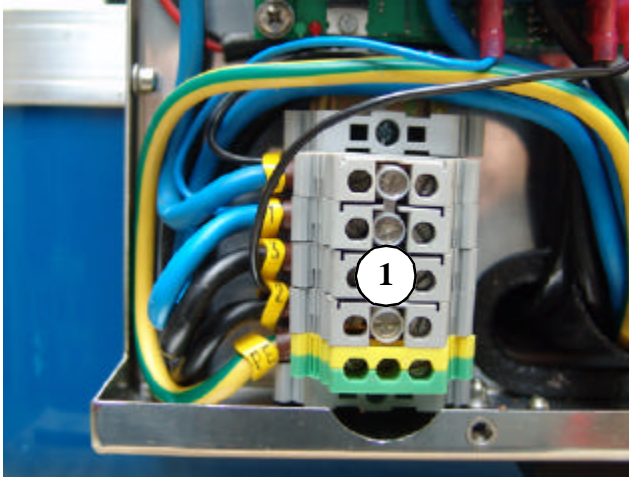

Load connection

At the back of the sound cover inside the control box is a terminal block. Connect here the load cable.

Fig. A.34: Load connection

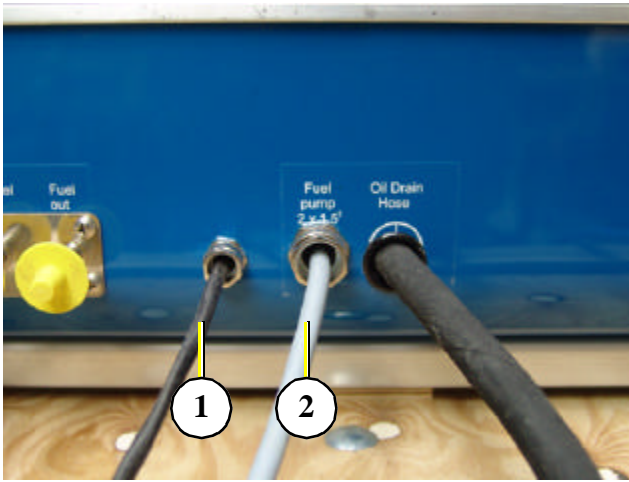

Connection external fuel sensor and fuel pump

At the front of the sound cover is the withdrawal for the cable for the fuel sensor and fuel pump.

1. Cable for fuel sensor
2. Cable for fuel pump

Fig. A.35: Fuel sensor and fuel pump connection

Connection external remote control panel

At the back of the sound cover inside the control box on the VCS circuit board is the panel communication port.

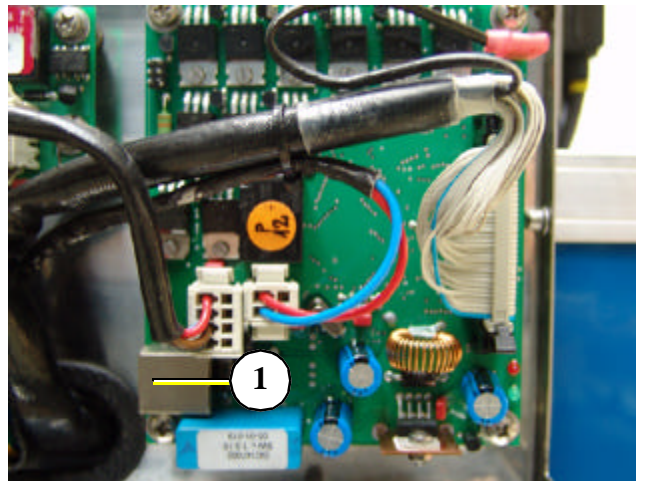

Fig. A.36: Remote control panel connection

Starter motor

1. Starter motor and
2. Solenoid switch

The Diesel engine is electrically started. On the back of the engine is accordingly the electrical starter with the solenoid switch.

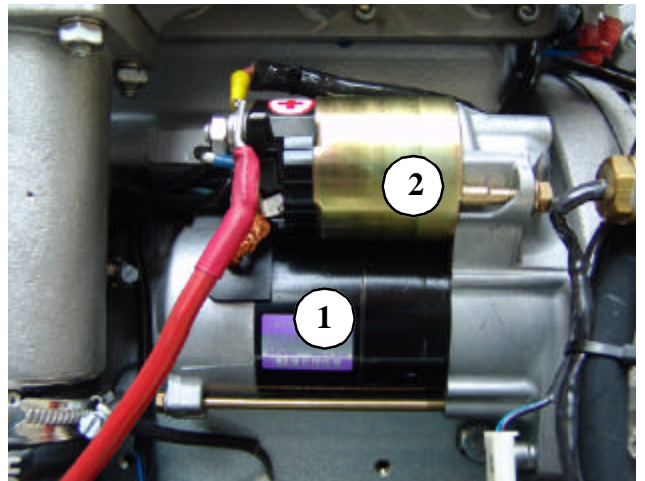

Fig. A.37: Starter motor

Actuator for speed regulation

The generator voltage is determined by progressive speed control through "VCS" in conjunction with the speed actuator. Speed increases with increasing load.

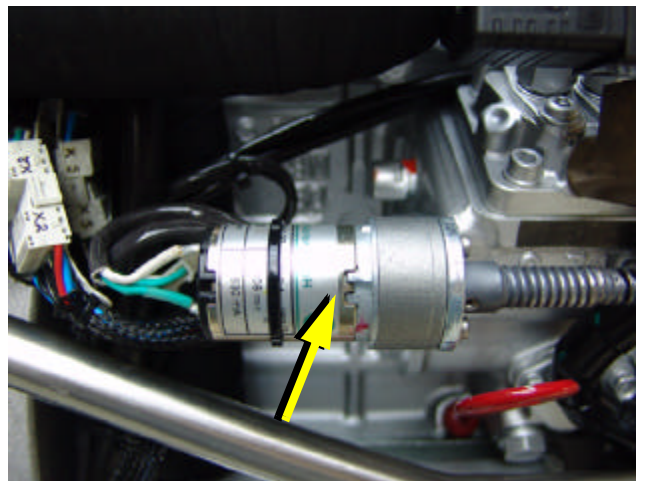
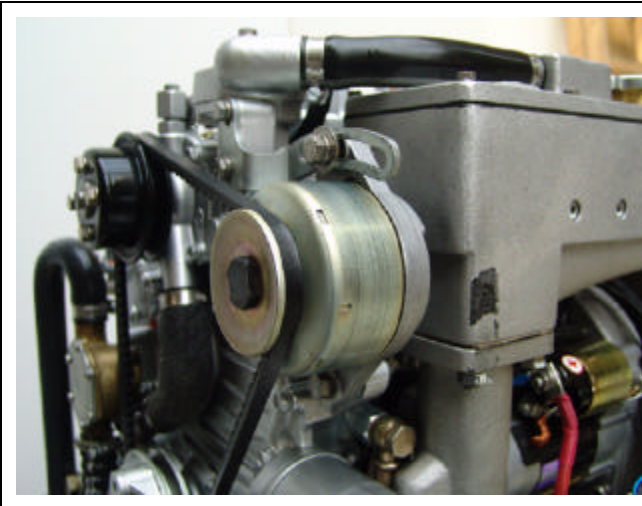

Fig. A.38: Actuator



DC-alternator

All Panda generators from Panda 6.000 are provided with its own charge system for the 12V DC mains. This DC-alternator is powered over a v-belt together with the internal cooling water pump.

The 12V charge system may be used only for the generator-own starter battery.

Fig. A.39: DC-alternator



Charge control for DC-alternator

The voltage regulator for the 12V DC alternator is on the back of the air suction housing. The housing is formed for cooling purposes. The voltage regulator may not be covered from the outside. The surface must be accessible for the cooling.

Fig. A.40: Charge controller

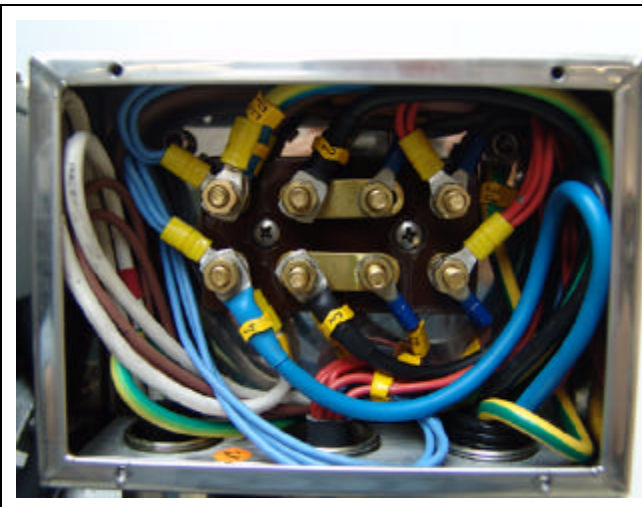

Generator power terminal box

At the back of the generator is the generator power terminal box. In this box the electrical connection points of the AC generator are connected. Here is also the bridge for the protective grounding of the generator. The cover may only be removed, if it is guaranteed that the generator cannot be inadvertently started.

Fig. A.41: Generator power terminal box

Relay board

On the relay board are mounted the relays and electrical fuses.

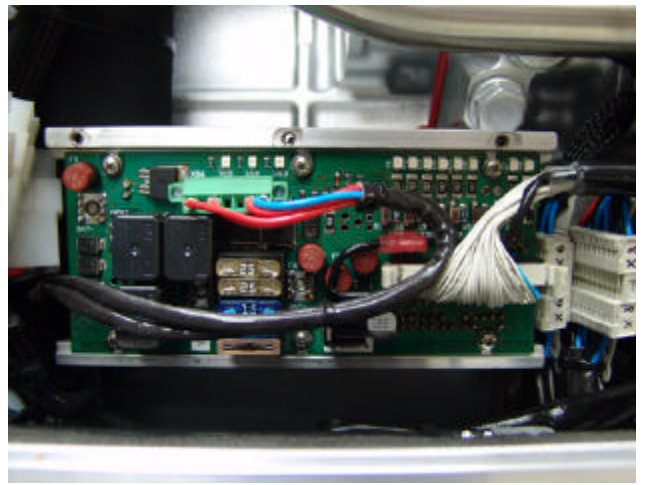

Fig. A.42: Relay board

Relays

- K1 power relay for Starter
- K2 power relay for Glow plug
- K3 power relay for Fuel pump

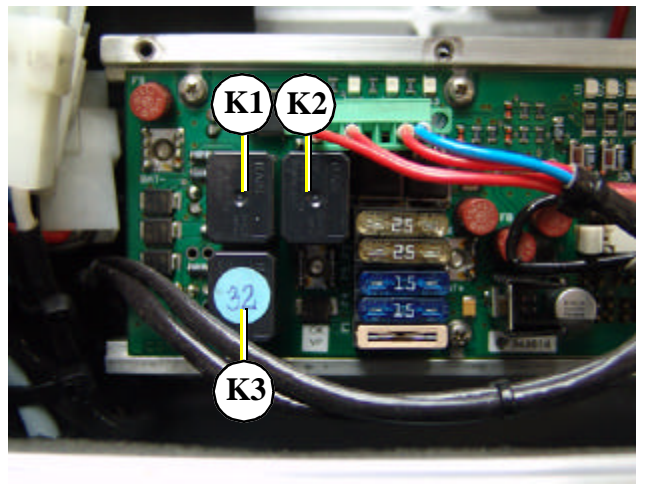

Fig. A.43: Relays

Fuses

- F1 fuse 5A for BAT+ connection
- F2 fuse 25A for relay K1 (start relay)
- F3 fuse 25A for relay K2 (glow plug)
- F4 fuse 15A for relay K3 (fuel pump)
- F5 fuse 15A for relay K5 (stop solenoid)

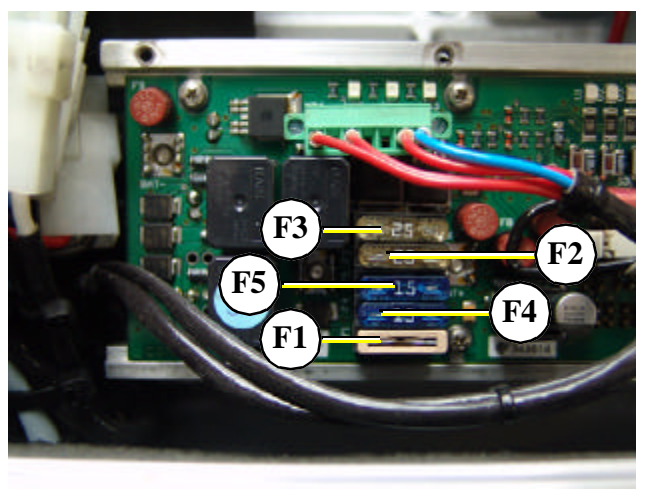

Fig. A.44: Fuses

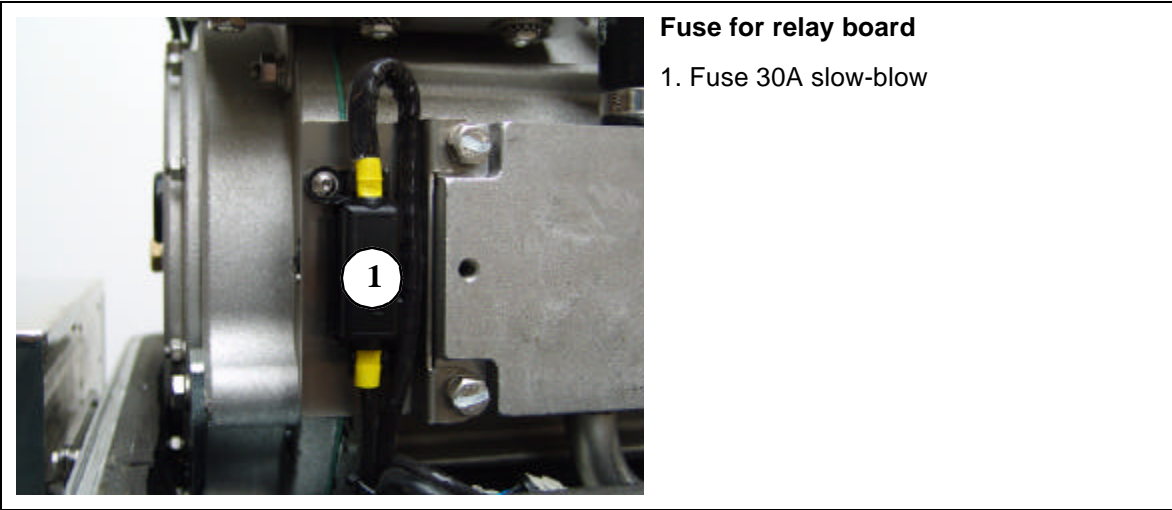

Fig. A.45: Fuse for relay board

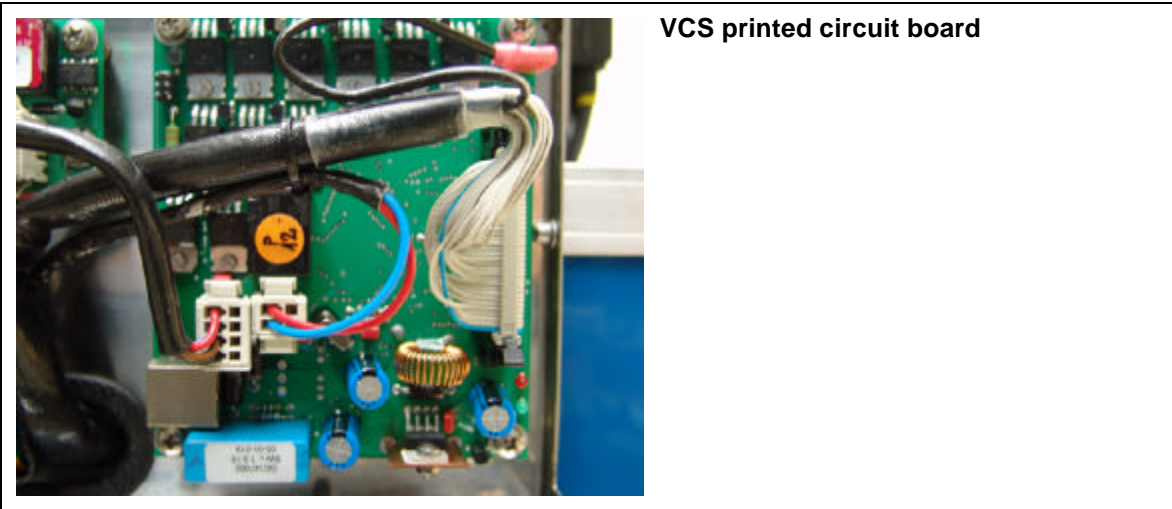

Fig. A.46: VCS

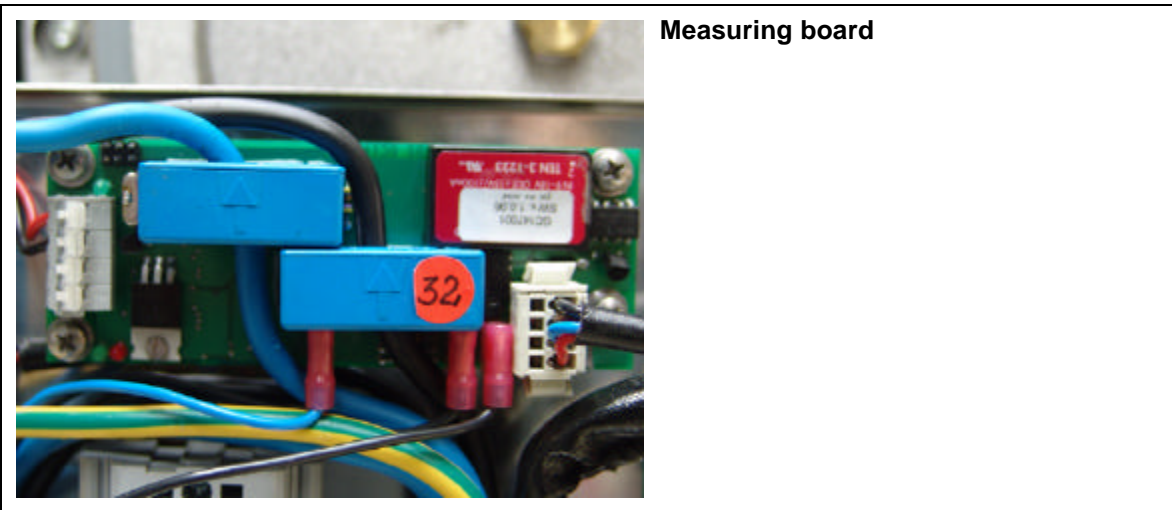

Fig. A.47: Measuring board

Booster capacitors

2x40 μ F



Fig. A.48: Booster capacitors

Excitation capacitors

2x140 μ F



Fig. A.49: Excitation capacitors

Solid state relays

2xSolid state relays for booster cpacitors.

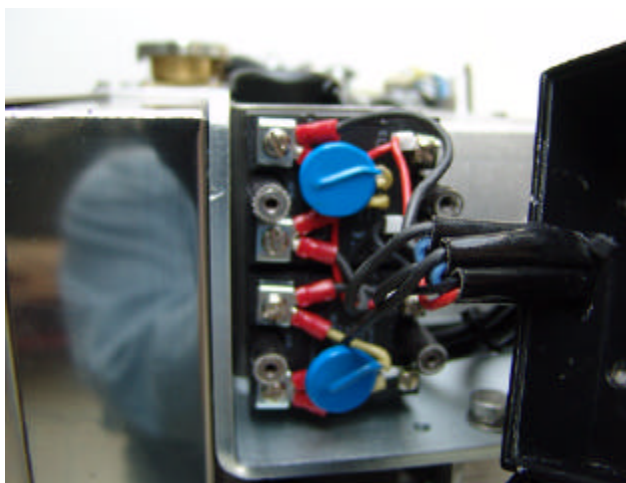



Fig. A.50: Solid state relays

A.2.7 Sensors and switches for operating surveillance



Thermo-switch at cylinder head

The thermo-switch at the cylinder head serves the monitoring of the generator temperature. All thermo-switches for the generators from Panda 6.000 upward are two-pole and laid out as "openers".

110°C and 130°C

Fig. A.51: Thermo-switch at cylinder head

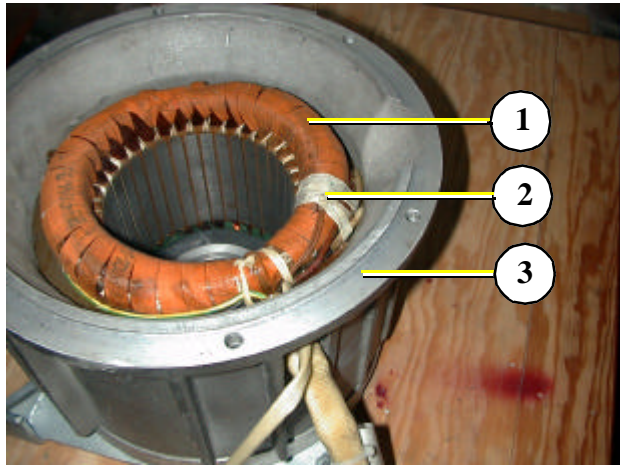

Thermo-switch in the generator coil

1. Generator coil
2. Thermo-switch 4x165°C
3. Housing

For the protection of the generator coil there are two thermo-switches inside the coil, which are for inserted parallel and safety's sake independently from each other.

Fig. A.52: Coil thermo-switch

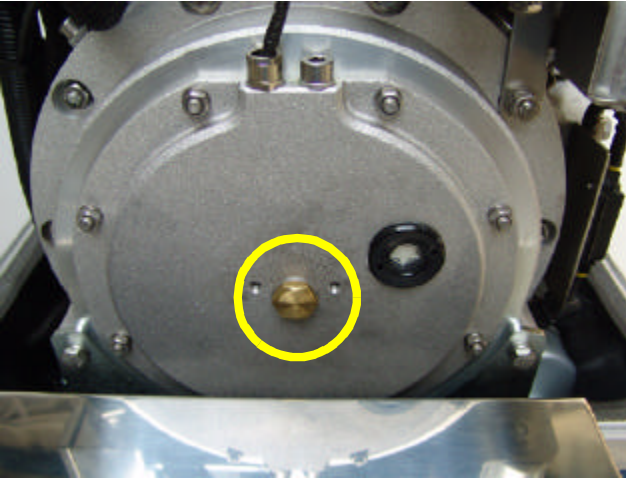

Thermo-switch at the oil lubricated bearing

The generator bearing is equipped with an oil thermostwitch, which switches the engine off if the oil temperature becomes to high.

130°C

Fig. A.53: Thermo-switch at front plate

**Thermo-switch at water-cooled
exhaust elbow**

120°C/105°C



Fig. A.54: Thermo-switch at exhaust elbow

Thermo-sensor exhaust port

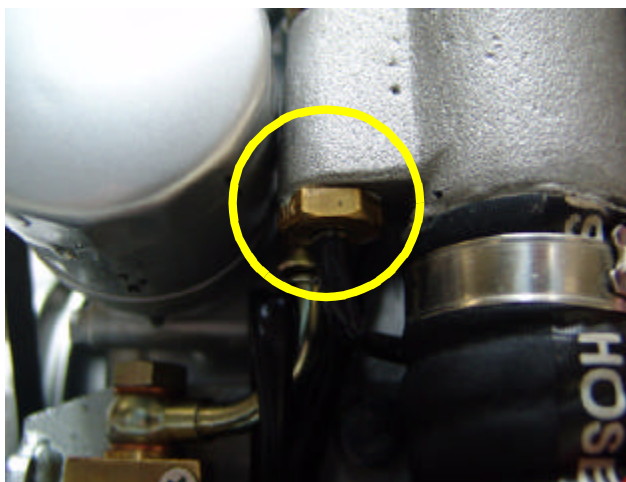

Fig. A.55: Thermo-sensor exhaust port

Thermo-sensor raw water in



Fig. A.56: Thermo-sensor raw water in

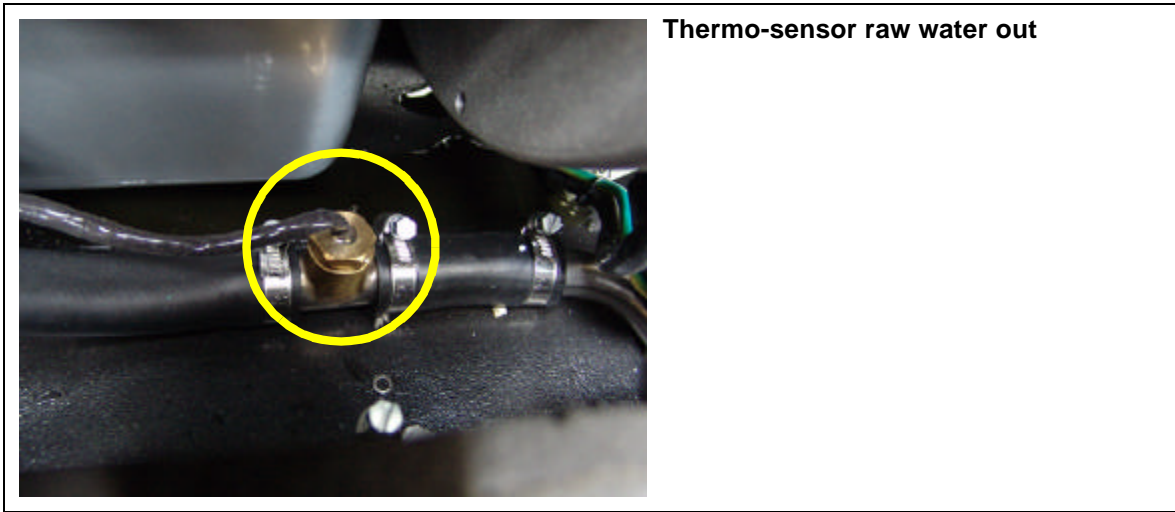

Fig. A.57: Thermo-sensor raw water out

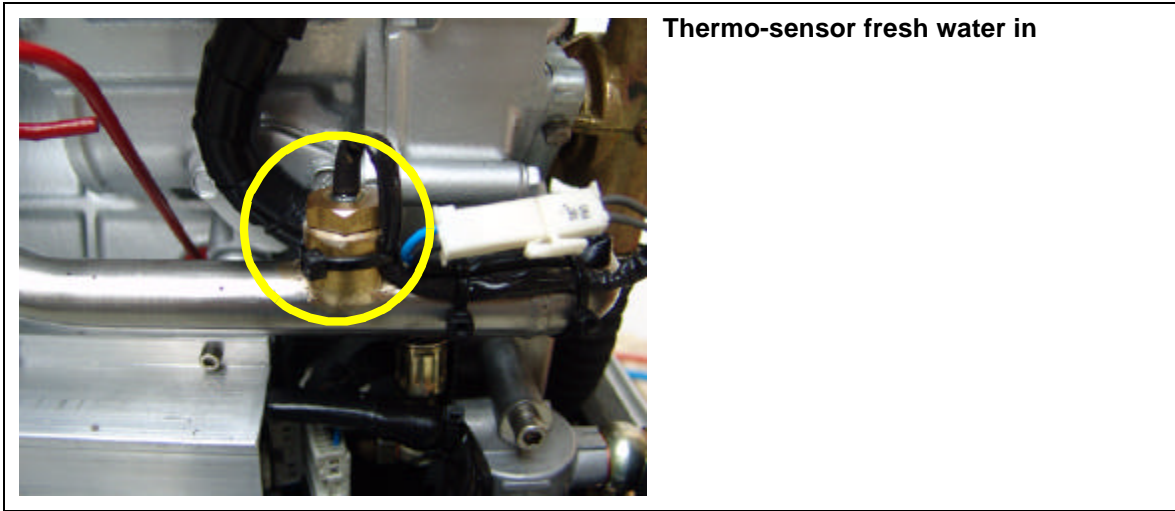

Fig. A.58: Thermo-sensor fresh water in

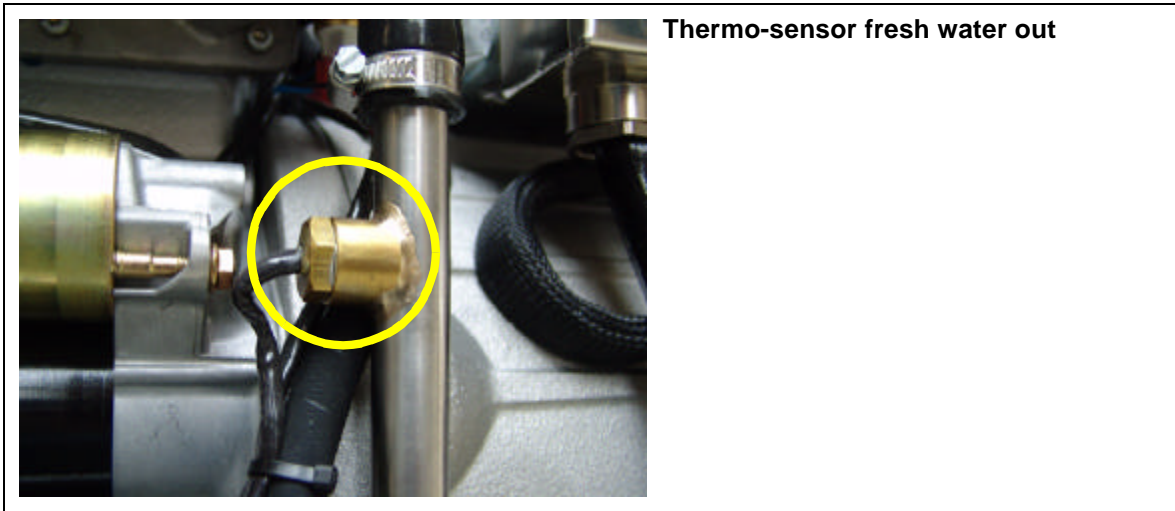

Fig. A.59: Thermo-sensor fresh water out

Oil sensor with oil pressure switch

In order to be able to monitor the lubricating oil system, an oil pressure switch is built into the system. The oil pressure switch is on the back of the engine (below the oil filter).

1. Oil sensor
2. Oil pressure switch

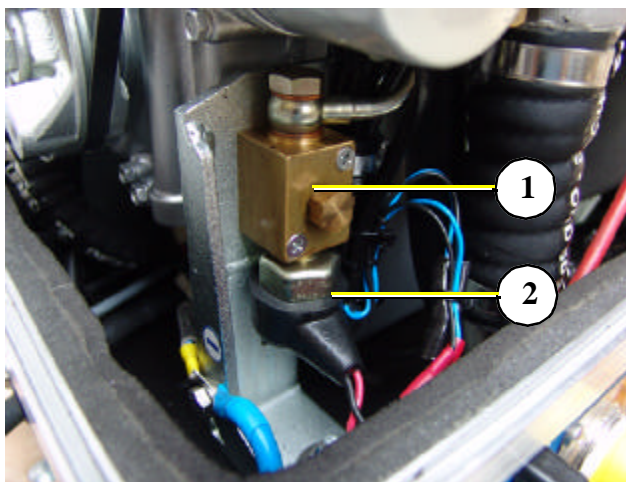

Fig. A.60: Oil sensor with oil pressure switch

Oil sensor at oil sump



Fig. A.61: Oil sensor at oil sump

A.2.8 Components of the oil circuit

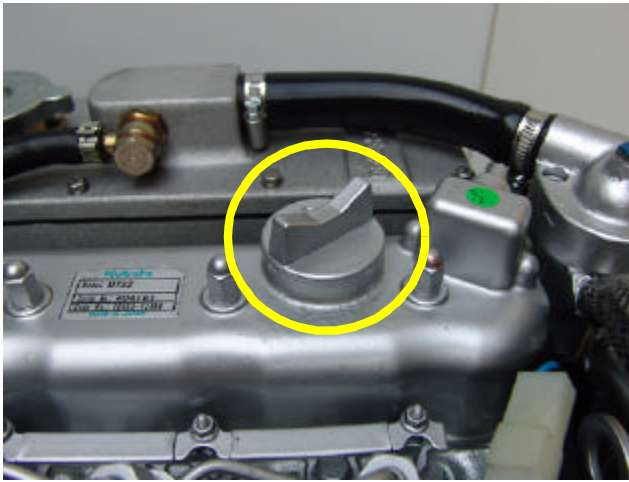

Oil filler neck with cap

Normally the filler neck for the engine oil is on the top side of the valve cover. At numerous generator types a second filler neck is attached additionally at the operating side. Please pay attention that the filler necks are always well locked after filling in engine oil.

Consider also the references to the engine oil specification.

Fig. A.62: Oil filler neck with cap

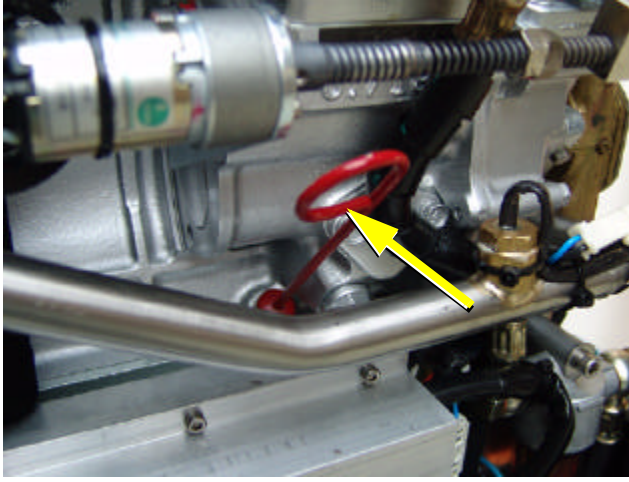

Oil dipstick

At the dipstick the permissible level is indicated by the markings "maximum" and "minimum". The engine oil should be never filled up beyond the maximum conditions.

Fig. A.63: Oil dipstick

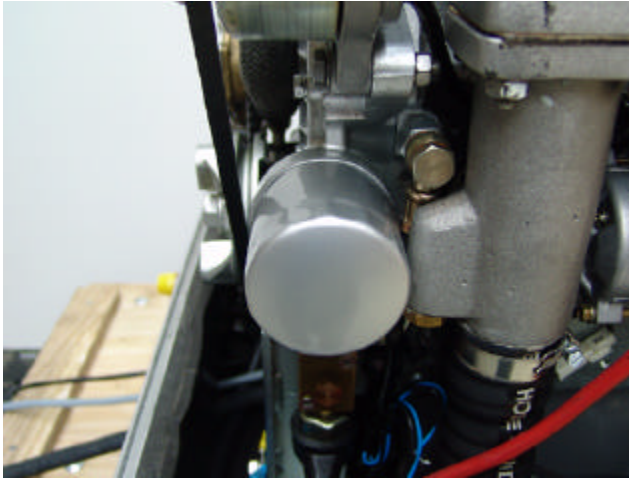

Oil filter

The oil filter should be exchanged with an oil change.

Fig. A.64: Oil filter

Oil drain hose

The Panda generator is equipped that the engine oil can be drained over an drain hose. The generator should be always installed therefore that a collecting basin can be set up deeply enough. If this is not possible, an electrical oil drain pump must be installed.

Note: Lubricating oil should be drained in the warm condition!

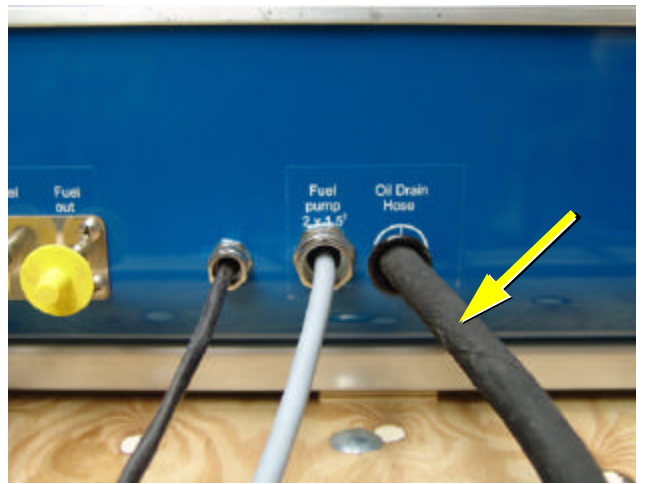

Fig. A.65: Oil drain hose

A.3 Operation manual

A.3.1 Preliminary remark

Tips regarding Starter Battery

Fischer Panda recommends normal starter battery use. If a genset is required for extreme winter conditions, then the starter battery capacity should be doubled. It is recommended that the starter battery be regularly charged by a suitable battery-charging device (i.e., at least every 2 Months). A correctly charged starter battery is necessary for low temperatures.

A.3.2 Daily routine checks before starting

1. Oil Level Control (ideal level: MAX).

ATTENTION! OIL PRESSURE CONTROL!

True, the diesel motor automatically switches off when there is a lack of oil, but it is very damaging for the motor, if the oil level drops to the lowest limit. Air can be sucked in suddenly when the boat rocks in heavy seas, if the oil level is at a minimum. This affects the grease in the bearings. It is therefore necessary to check the oil level daily before initially running the generator. The oil level must be topped up to the maximum level, if the level drops below the mark between maximum und minimum levels.

The oil level of the oil cooled bearing must be checked before every start - see flow glas at the generator front cover .



2. State of Cooling Water.

The external compensation tank should be filled up to a maximum of in a cold state. It is very important that large expansion area remains above the cooling water level.

3. Open Sea Cock for Cooling Water Intake.

For safety reasons, the seacock must be closed after the generator has been switched off. It should be re-opened before starting the generator.

4. Check Raw Water Filter.

The raw water filter must be regularly checked and cleaned. The impeller fatigue increases, if residual affects the raw water intake.

5. Check all Hose Connections and Hose Clamps are Leakage.

Leaks at hose connections must be immediately repaired, especially the raw water impeller pump. It is certainly possible that the raw water impeller pump will produce leaks, depending upon the situation. (This can be caused by sand particles in the raw water etc.) In this case, immediately exchange the pump, because the dripping water will be sprayed by the belt pulley into the sound insulated casing and can quickly cause corrosion.

6. Check all electrical Lead Terminal Contacts are Firm.

This is especially the case with the temperature switch contacts, which automatically switch off the generator in case of faults. There is only safety if these systems are regularly checked, and these systems will protect the generator, when there is a fault.

7. Check the Motor and Generator Mounting Screws are Tight.

The mounting screws must be checked regularly to ensure the generator is safe. A visual check of these screws must be made, when the oil level is checked.

8. Switch the Land Electricity/Generator Switch to Zero before Starting or Switch Off all the load.

The generator should only be started when all the load have been switched off. The excitation of the generator will be suppressed, if the generator is switched off with load connected, left for a while, or switched on with extra load, thus reducing the residual magnetism necessary for excitation of the generator to a minimum. In certain circumstances, this can lead to the generator being re-excited by means of a DC source. If the generator does not excite itself when starting, then excitation by means of DC must be carried out again.

9. Check the Automatic Controls Functions and Oil Pressure.

Removing a cable end from the monitoring switch carries out this control test. The generator should then automatically switch off. Please adhere to the inspection timetable (see Checklist in the appendix).

A.3.3 Starting Generator

1. If necessary, open the fuel valve.
2. If necessary, close the main battery switch.
3. Check if all the load have been switched off.

The load is switched off, before the generator is switched off. The generator is not to be started with load connected. If necessary, the main switch or fuse should be switched off or the load should be individually switched off.

4. Press Standby-switch „ON/OFF“ (Position 2 on control panel).

Control light for "Stand by" Button must light up.

5. Press "RUN/STOP" button Generator (Position 06 on control panel).

After the automatic pre-glow phase the engine starts.
The electric starter may only be used for a maximum of 20 seconds. Thereafter, a pause of, at least, 60 seconds is required. If the genset does not immediately start, then the fuel intake should be checked to ensure it is flowing freely. (For temperatures below - 8°C check whether there is winter fuel)

6. Check circuit-voltmeter and frequency is within the tolerance rage
7. Switch on load.

A.3.4 Stopping the Generator

1. Switch off load.
2. If the load is higher than 70% of the nominal load, the generator temperatures should be stabilised by switching off the load for at least 5 minutes.

At higher ambient temperatures (more than 25°C) the generator should always run for at least 5 minutes without load, before it is switched off, regardless of the load.

3. Press „RUN/STOP“ button and switch off the generator.
4. Activate additional switches (Battery switch, fuel stop valve etc.).

NOTE: Never switch off the battery until the generator has stopped.

5. If necessary, close sea cock.

B. E-Tec Remote control panel

The remote control panel is equipped with some monitoring functions, which increases the operational safety of the generator. A failure message is shown over contacts which are normally closed. If a connection is intermitted triggers this a failure message.

There are two different displays:

- 1) The „Engine view“, which shows you the engine relevant datas like temperatures.
- 2) The „Generator view“, which shows you the generator relevant datas like voltages.

To Start the Engine:

- 1.) Press the „Standby“-Switch (02) - the LED below the button has to come up.

You should see a display that looks like the one beneath.

- 2.) Press the „run/stop“ button (06) (after the automatic pre-glow phase the engines starts)

The LED below the button blinks during the start procedure, when the engine has started the LED flashes constant.

First the generator runs in idle-speed for the predefined period.

Than the engine runs up to the normal rotation speed.

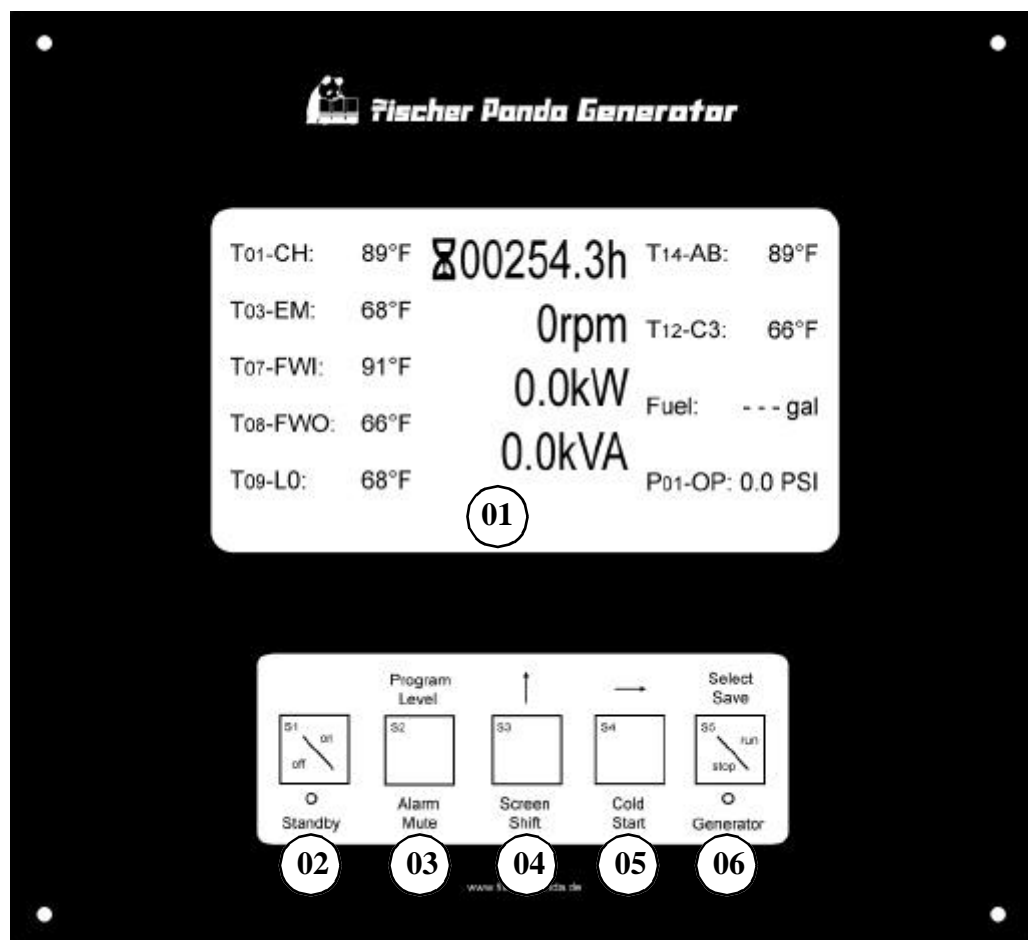

01. Digital display

02. S1 Button „ON/OFF“ „Stand by“

03. S2 Button alarm mute / program level

04. S3 Button display shift

05. S4 Button rpm shift / cold start

06. S5 Button run/stop / select save

Panel „Engine view“ in Stand by mode

T01-CH: 89°F	⌚ 00254.3h	T14-AB: 89°F	
T03-EM: 68°F	0rpm	T12-C3: 66°F	
T07-FWI: 91°F	0.0kW	Fuel: --- gal	
T08-FWO: 66°F	0.0kVA	P01-OP: 0.0 PSI	
T09-LO: 68°F			

L.O. prss. switch P09

T01-CH: Cylinder head
 T02-EM: Exhaust manifold
 T07-FWI: Freshwater - in
 T08-FWO: Freshwater - out
 T09-LO: Lubricating oil
 T14-AB: Alternator bearing
 T12-C3: Temperatur at coil 3
 (display changes - only the coil with the the highest temperature)
 P01-OP: Oil-pressure

„- - -“ means that the sensor isn't connected or a cable is broken.

Panel „Generator view“ in Stand by mode

01	02	03	04
0rpm	⌚ 00254.3h	0.0 Hz	
U1: 0V	0.0kVA	I1: 0A	
U2: 0V	▬ %	I2: 0A	
U3: 0V	0.0KW	I3: 0A	
PF: 1.00i	Bs: 26.5 V	C2: 0 %	
T01: 89°F		T10: 89°F	

L.O. prss. switch P02

01: rounds per minute
 02: elapsed hours
 03: apparent power
 04: frequency 0Hz
 05: status line(s)
 06: effective power with bar line

PF: active power factor
 Bs: battery voltage
 C2: compensation level
 Un: phase voltage
 In: phase current

Panel „Engine view“ when unit is running without load

T01-CH: 89°F	⌚ 00254.3h	T14-AB: 91°F	
T03-EM: 91°F	3529rpm	T12-C3: 98°F	
T07-FWI: 68°F	0.0kW	Fuel: --- gal	
T08-FWO: 95°F	0.0kVA	P01-OP: 58 PSI	
T09-LO: 89°F			

After pressing start and after the automatic pre-glow phase, the generator runs in idle-speed.

The engine runs up to the normal rotation speed of about 3529rpm.

The temperatures at the different test points begin to change.

Oil pressure shows 58 PSI.

Panel „Generator view“ when unit is running without load

The rotation speed keeps constant at approx. 3500rpm

Now you can see the voltages at the separat phases.

Values for kVA and kW are 0, because the generator runs without load.

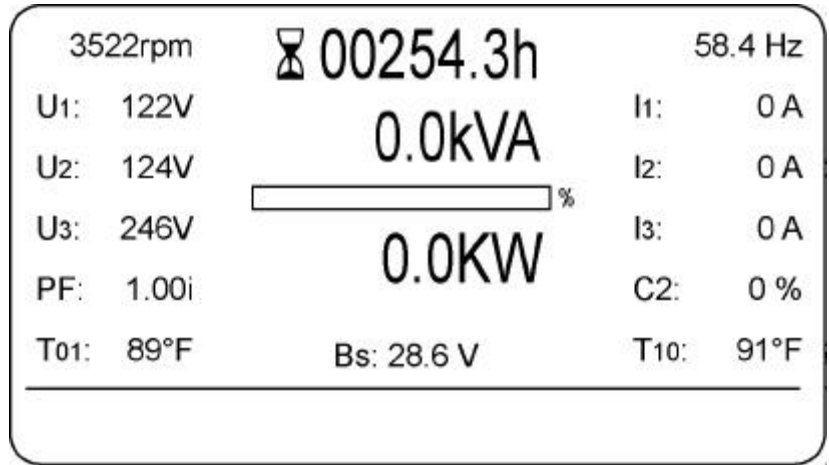

Panel „Engine view“ in case of warning

T01-CH, the cylinder head - temperature has reached 232°F. The other temperatures are inside the permissible range.

A warning „Temp. cyl head“ occurs at the lower left side of the panel.

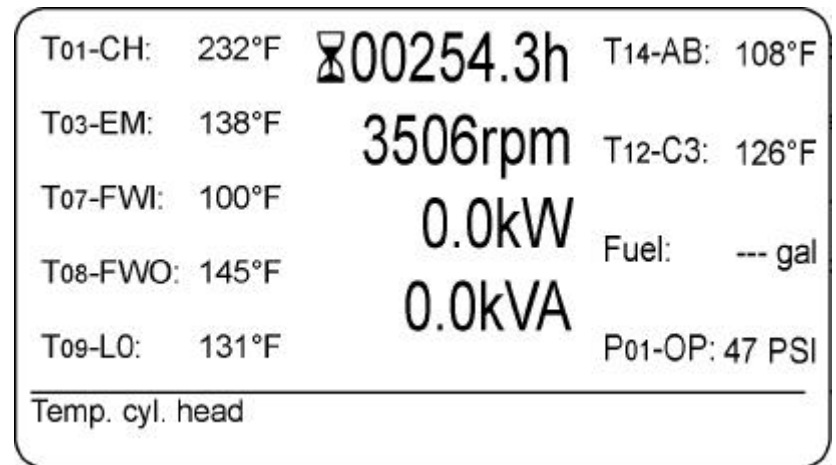

Panel „Engine view“ in case of error

T01-CH, the cylinder head - temperature has reached 252°F. The other temperatures are inside the permissible range.

A warning „Temp. cyl head“ occurs at the lower left side of the panel.

Additionally, a failure comes at the lower right side.

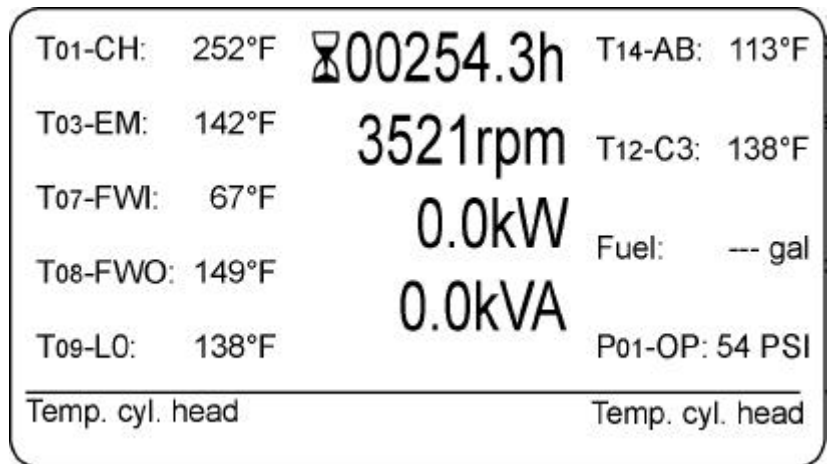

Panel „Engine view“ after error-caused shutdown

T01-CH: 491°F	⌚ 00254.3h	T14-AB: 95°F	
T03-EM: 122°F	0rpm	T12-C3: 106°F	
T07-FWI: 68°F	0.0kW	Fuel: --- gal	
T08-FWO: 491°F	0.0kVA	P01-OP: 0.0 PSI	
T09-L0: 89°F			
Frequency		Voltage low	
Lube oil press		Lube oil press	

The engine shuts down and the two status lines show different warnings and failures.

Naturally, there aren't 491°F at the T01 or T08. This value says that the temperature is too high and the engine has shut down.

Program mode for panel parallel switching

ATTENTION: It is not allowed to program two panels at the same time. Program first one panel and then the second.

To get into the „Program mode“ press the buttons „Program Level (S2)“ and „Display shift (S3)“ at the same time.

Display:	US standard (metric)
Address:	0 (1-7)
Nominal power:	0200 x0.1kW

In this mode you must adjust the panel for parallel switching.

To change the settings use button S3 and to scroll use button S2.

The „Display“ must be switched to „US standard“.

The first panel get the „Address 0“.

The second panel get the „Address 1“

To store this settings press the button „Select Save“.

An failure override button enables an immediate restart facility of the generator, should it cut out, even if this was caused by over-heating. There is normally a requirement to wait until the motor has cooled down to the correct temperature. This can last for several hours in certain circumstances, since the generator is enclosed in a sound-insulated casing, which prevents heat loss.

This period can be reduced by pushing the „Alarm Mute“ button. By pressing the button all faults are overridden for 10 seconds. When the button is pressed again during the 10 seconds, 10 seconds will be added to the remaining time. The generator can be started. The button bypasses any faults allowing the generator to run.

Before depressing the button, a manual check of the oil dipstick must be carried out to determine whether the generator has sufficient oil, as it is possible that the oil pressure switch causes the generator to cut out. If it has been ascertained that the reason for the motor cutting out is overheating and not lack of oil, the generator can be run for several minutes without load, so that the motor is cooled by the circulating coolant.

ATTENTION:

If the temperature is the reason for the generator cutting out when it is running under load, then an immediate check must be made to determine the cause. It could be a fault with the cooling system, one of the fans, the air-intake or a fault with the external cooling system.

Continual use of the starter-override switch should be avoided, while the generator cuts out during operation. The generator must always run without load for several minutes before being switched off, so that a temperature compensation occurs. Heat accumulation can cause the generator to overheat, even after it has been switched off.

Should the overheating alarm be set off, caused by heat accumulation, after the generator has been switched off, then this can also be bypassed using the switch.

Push:

„Alarm Mute“ to acknowledge

again „Alarm Mute“ to deactivate all sensors and

„Motor Start“ to restart the engine

